

OPERATION MANUAL

DIGITAL STORAGE OSCILLOSCOPE

MODEL DSS5040

Second Edition

Notes for Versions

This manual can be applied for the instruments with serial number of XXXX2205 and above. Refer to the following description for the changes.

Sine interpolation: Instead of the SIN X/X filter interpolation, a spline interpolation with polynomials is employed.

Trigger position: Uncertainty errors within one-sampling section may (Storage mode) occur at the high sweep speed ranges in the single-shot mode.

KIKUSUI ELECTRONICS CORPORATION

7.4.2
8:36:48 B

Power Requirements of this Product

Power requirements of this product have been changed and the relevant sections of the Operation Manual should be revised accordingly.

(Revision should be applied to items indicated by a check mark)

Input voltage

The input voltage of this product is _____ VAC,
and the voltage range is _____ to _____ VAC. Use the product within this range only.

Input fuse

The rating of this product's input fuse is _____ A, _____ VAC, and _____.

WARNING

- To avoid electrical shock, always disconnect the AC power cable or turn off the switch on the switchboard before attempting to check or replace the fuse.
- Use a fuse element having a shape, rating, and characteristics suitable for this product. The use of a fuse with a different rating or one that short circuits the fuse holder may result in fire, electric shock, or irreparable damage.

AC power cable

The product is provided with AC power cables described below. If the cable has no power plug, attach a power plug or crimp-style terminals to the cable in accordance with the wire colors specified in the drawing.

WARNING

- The attachment of a power plug or crimp-style terminals must be carried out by qualified personnel.

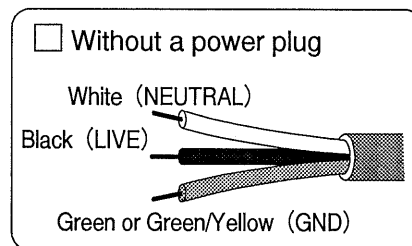
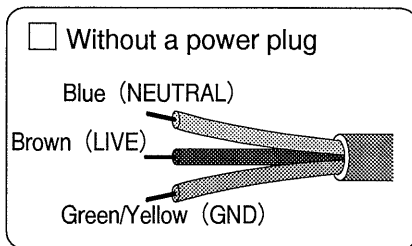

- o Resetting the Oscilloscope

When an erroneous operation (erroneous setting) of the oscilloscope is suspected, reset it by turning OFF power once and then turning it ON again. This will reset the oscilloscope (CPU) to the normal state. If it is not reset, contact your Kikusui agent for service.

TABLE OF CONTENTS

	<u>PAGE</u>
1. GENERAL	1
2. SPECIFICATIONS	3
3. GENERAL PRECAUTIONS	13
4. DESCRIPTION OF PANELS	16
4.1 Description of Front Panel	16
4.2 Description of Rear Panel	30
5. BASIC OPERATION METHOD	31
5.1 AC Line Voltage Setting	31
5.2 To Display a Trace on the CRT	31
5.3 To Align the Trace With the Graticule Line	33
5.4 Calibration of Probe	34
6. MEASUREMENTS OF WAVEFORM	35
6.1 Measurement in Real Mode	35
(1) Single-channel Operation	35
(2) Dual-channel Operation	36
(3) To Add Two Waveforms	39
(4) To Use as an X-Y Scope	40
(5) Triggering	43
(6) Single-sweep Operation	53
(7) Sweep Magnification	56
6.2 Measurement in Storage Mode	57
(1) Waveform Measurement in Storage Mode	58
(2) To Save Waveform	62
(3) To Magnify the Saved Waveform	62
(4) To Compare Waveforms	63
(5) To Save Waveform in Single-sweep Mode	64
(6) To View Waveform Existed Before Triggering	64

863729

	<u>PAGE</u>
7. OPERATING PRINCIPLE	70
7.1 Basic Principle of Digital Storage Oscilloscope	70
7.2 Circuit Structure	71
8. MAINTENANCE AND STORING	74

863730

1. GENERAL

The DSS5040 is a portable dual-channel digital storage oscilloscope. It is incorporated with an 8-bit CPU, renders a maximum sampling rate of 25 MHz and an effective storage frequency of 7 MHz, has a memory capacity of 1024 words per channel, and is able to be used as a dual-channel digital storage oscilloscope with interpolation of data saved in the memory, or is able to be used as a real-time oscilloscope of 20 MHz. The most outstanding features of the DSS5040 are as follows:

- (1) Effective storage frequency range of DC - 7 MHz

Interpolation can be done for both sinusoidal waves and pulse waves and consequently even one-shot sinusoidal waves can be accurately displayed.

- (2) Waveform magnification

The saved waveforms can be displayed being magnified by up to 100 times, from one of three selectable points.

- (3) PEN OUT provision

The saved waveform data can be delivered with speeds which automatically changes depending on waveform, allowing you to obtain rapidly and accurately a hardcopy employing a pen recorder.

- (4) Useful functions

The various useful functions such as for comparison of waveforms and measurement of slow speed signals, one-shot events, and signals before the triggered point are incorporated.

- (5) A trigger level lock function which makes triggering adjustment procedure unnecessary

A new trigger level lock circuit is incorporated. This circuit eliminates the requirement of troublesome triggering adjustment procedure not only for display of regular signals but also for that of video signals and large duty cycle ratio signals.

100 8 24
863731A

(6) 40-MHz dual-channel real time oscilloscope

The DSS 5040 is a version of the COS5040 whose performance has been proven. The DSS 5040 can be used as a quality real oscilloscope.

(7) Compact, light, but sturdy

The oscilloscope is made of styren acrylonitrile butadiene and steel plates. It is compact, light, but sturdy.

863732

2. SPECIFICATIONS

(1) Vertical axes

- o Real mode (The same applies also to the storage mode unless specified otherwise.)

Item	Specification	Remarks
Sensitivity	NORM: 5 mV/DIV - 5 V/DIV ×5 MAG: 1 mV/DIV - 1 V/DIV	1-2-5 sequence, 10 ranges
Sensitivity accuracy	NORM: ±3% or better ×5 MAG: ±5% or better	10 to 35°C (50 to 95°F), 1 kHz, at 4 or 5 DIV Otherwise if in storage mode
Vernier vertical sensitivity	To 1/2.5 or less of panel-indicated value	
Frequency bandwidth	NORM: DC - 40 MHz, within -3 db ×5 MAG: DC - 20 MHz, within -3 dB AC coupling: Low limit frequency 10 Hz, -3 dB	With reference to 50 kHz, 8 DIV Otherwise if in storage mode
Rise time	NORM: 8.75 nsec or less ×5 MAG: 17.5 nsec or less	Otherwise if in storage mode
Input impedance	1 MΩ ±2%, 28 pF ±2 pF	
Display mode	CH1	CH1 single channel
	CH2	CH2 single channel
	DUAL	CHOP: 1 sec/DIV - 1 msec/DIV ALT: 0.5 msec/DIV - 0.5 μsec/DIV
	ADD	CH1 ± CH2
Chopping repetition frequency	200 kHz ±0.02%	Otherwise if in storage mode
Input coupling	AC-GND-DC	

Item	Specification	Remarks
Polarity change	CH2 only	
CH1 signal output	Approx. 100 mV/DIV when open; approx. 50 mV/DIV when 50-ohm termination	
Maximum allowable input voltage	400 V _{peak} (DC + AC peak)	AC: 1 kHz or lower

o Storage mode

Item	Specification	Remarks
A/D converter	8-bit half-flush type	
Maximum sampling speed	25M samples/sec	
Vertical resolution	8 bits, 28 points/DIV, 9.14 DIV dynamic range	
Sensitivity accuracy	NORM: ($\pm 3\%$) + 1 LSB or better $\times 5$ MAG: ($\pm 5\%$) + 1 LSB or better	
Effective storage bandwidth	NORM: DC - 7 MHz $\times 5$ MAG: DC - 7 MHz	When sine interpola- tion is used.
Effective rise time	80 nsec or faster	When pulse interpola- tion is used.
Chopping repeti- tion	50 Hz - 50 kHz, depending on TIME/DIV range	

(2) Triggering

- o Real mode (The same applies also to the storage mode unless specified otherwise.)

Item	Specification	Remarks
Signal source	INT, LINE, EXT	
Internal triggering source select	CH1, CH2, and VERT MODE When in VERT MODE, triggering source depends on vertical channel being used. When in ADD mode, CH1 signal is used as triggering source signal.	VERT MODE is effective only when in ALT or SINGLE sweep mode. Triggering is adjustable with LEVEL control.
Coupling	AC, HF REJ, TV, DC	
Polarity	+ or -	
Sensitivity	DC - 10 MHz: 0.5 DIV (0.1 V) DC - 40 MHz: 1.5 DIV (0.2 V) Video signal: 2.0 DIV (0.2 V) AC coupling: Attenuates signal components of lower than 10 Hz HF REJ: Attenuates signal components of higher than 50 kHz	The values enclosed in the parentheses are the input sensitivities when in the EXT triggering mode. The specifications of DC - 10 MHz and DC - 40 MHz are applicable to real mode only.
Triggering modes	AUTO: Sweep runs in the free mode when no triggering input signal is applied.	Meets trigger sensitivity specification for signals of 50 Hz or higher.
	NORM: When no triggering signal is applied, the trace is in the READY state and not displayed.	Otherwise if in storage mode
	SINGL: One-shot sweep with trigger signal. Can be reset to the READY state by means of RESET switch. The READY lamp (LED) turns on when in the READY state or in the sweep operation.	Otherwise if in storage mode

863735

Item	Specification	Remarks
LEVEL LOCK	Satisfies the value of the above trigger sensitivity plus 0.5 DIV (0.05V). At sine wave (50 Hz - 40 MHz).	Repetition frequency 50 Hz - 10 kHz if in storage mode
EXT triggering signal input	EXT HOR input terminal is used in common.	Applicable to real mode only
Input impedance	1 MΩ ±2%, approx. 25 pF	
Maximum allowable input voltage	100 V _{peak} (DC + AC peak)	AC: 1 kHz or lower

o Storage mode

Item	Specification	Remarks
Triggering sensitivity	DC - 10MHz: 0.5 DIV (0.1 V)	
Triggering modes	NORM: When triggering has become ineffective, the displayed waveform remains as saved with previous triggering and the circuit remains ready to accept triggering.	If in the ROLL mode, newly stored waveform is displayed even when in the READY state.
	SINGL: Waveform for one-shot sweep cause by triggering is automatically saved. When saving is reset, the circuit again becomes the REDAY state. The READY lamp (LED) turns on when in the READY state or in sweep operation.	If in the ROLL mode, newly stored waveform is displayed even when in the REDAY state.
Predelayed triggering point	Horizontal: 2 DIV, 5 DIV, or 8 DIV point	

100.8.20

863736A

(3) Horizontal axis (Time base)

- o Real mode (The same applies also to the storage mode unless specified otherwise.)

Item	Specification	Remarks
Sweep time	NORM: 0.2 μ sec - 1 sec/DIV	1-2-5 sequence, 21 ranges
Sweep time accuracy (1)	$\pm 3\%$	10 to 35°C (50 to 95°F) Accuracy of sweep time for 8 divisions in graticule center
Sweep time accuracy (2)	$\pm 3\%$	10 to 35°C (50 to 95°F) When one time marker is assigned to each graticule division and the 2nd and 10th markers are aligned to the graticule lines, accuracy of each marker with respect to the 10 divisions, except the 1st and 11th markers.
Vernier sweep time control	To 1/2.5 or slower of panel-indicated value	Applicable to real mode only
Holdoff time	Continuously variable	Applicable to real mode only
Sweep magnification	10 times	
Magnified sweep time accuracy (1)	0.5 μ sec - 1 sec/DIV: $\pm 5\%$ 0.2 μ sec/DIV: $\pm 8\%$	10 to 35°C (50 to 95°F) Accuracy of sweep time for 8 divisions in graticule center, excluding 10%-portions from both end of sweep

863737

Item	Specification	Remarks
Magnified sweep time accuracy (2)	0.5 μ sec - 1 sec/DIV $\pm 5\%$ 0.2 μ sec/DIV: $\pm 8\%$	10 to 35°C (50 to 95°F) When one time marker is assigned to each graticule division and the 2nd and 10th markers are aligned to the graticule lines, accuracy of each marker with respect to the 10 divisions, excluding the 1st and 11th markers and 10% portions from both ends of sweep
EXT HOR mode	Trace swept by an external horizontal signal applied to the EXT TRIG IN terminal. Vertical axis modes are CH1, CH2, DUAL and ADD modes (indicated).	Applicable to real mode only
Sensitivity	Approx. 0.1 V/DIV	
Frequency bandwidth	DC - 1 MHz (-3dB)	
Phase difference between vertical axes	Within 3° (at DC - 50 kHz)	

o X-Y mode (Real mode only)

Item	Specification	Remarks
Inputs	X-axis: CH1 input signal Y-axis: CH2 input signal	
X-axis sensitivity	Same as CH1 vertical axis	
Sensitivity	NORM: $\pm 4\%$ $\times 5$ MAG: $\pm 6\%$	10 to 35°C (50 to 95°F) 1 kHz, at 4 or 5 DIV
Frequency bandwidth	DC - 1 MHz (-3db)	

MS 52045

87.9.28

863738A

Item	Specification	Remarks
Y-axis sensitivity	Same as CH2 vertical axis	
Sensitivity accuracy	Same as CH2 vertical axis	
Frequency bandwidth	Same as CH2 vertical axis	
X-Y phase difference	Within 3° (at DC - 50 kHz)	

o Storage mode

Item	Specification	Remarks
Horizontal resolution	10 bits/channel, 100 points/div, 1024 points	
Sampling speed	100 samples/sec - 25M samples/sec	Sampling speed at 1 sec - 0.2 μ sec/DIV depends on TIME/DIV setting. At 1 μ sec - 0.2 μ sec/DIV, sampling speed is fixed at 25 M samples/sec and waveform is expanded by interpolation.
Accuracy of sampling speed	0.02%	
ROOL mode	Automatic switching of 1 sec - 0.1 sec/DIV range	
Time base magnification by interpolation	Up to 100 times of time base on which data has been save from the above time base	Magnification is done with reference to the portion selected by triggering point
Type of interpolation	Sine interpolation and pulse interpolation	

Item	Specification	Remarks
SAVE mode	As you press the SAVE switch, the oscilloscope is set to the SAVE mode and data being acquired is saved.	
REFERENCE	As you press the REF switch, data is stored with reference to the waveform currently displayed on the CRT screen. As you press the REF switch again, the REFERENCE state is released.	Not applicable when in the DUAL mode
VIEW TIME	Approx. 0.5 sec - 5 sec, continuously variable	Excluding arithmetic processing time
PEN OUT function	As PEN switch is pressed when in SAVE mode, signal for displayed waveform is delivered. As PEN switch is pressed again, signal is reset.	
Output voltage	X-, Y-axis: 0.1 V/DIV Sync: TTL, positive	
Output impedance	X-, Y-axis: Approx. 200 Ω Sync: Approx. 470 Ω	
Output voltage accuracy	$\pm 10\%$ or better of value displayed on CRT	
Pen speed	Automatically variable for approx. 55 msec - 4.4 sec in response to difference with respect to subsequent data	

(4) Z axis

Item	Specification	Remarks
Sensitivity	3 Vp-p (Trace becomes brighter with negative input.)	
Frequency range	DC - 5 MHz	
Input resistance	Approx. 5 k Ω	
Allowable input voltage	50 Vpeak (DC + AC peak)	AC; 1 kHz or lower

Job 161.05 2/1 英里 DSS 5040

(5) Calibration voltage

Item	Specification	Remarks
Waveform	Positive square wave	
Frequency	1 kHz $\pm 20\%$	
Output voltage	0.5 V _{p-p} , $\pm 2\%$	
Output resistance	Approx. 500 Ω	

(6) CRT

Item	Specification	Remarks
Type	6-inch rectangular type internal graticule	
Phosphor	P31	
Acceleration voltage	Approx. 12 kV	
Effective screen size	8 \times 10 DIV	1 DIV = 10 mm (0.39 in.)
Graticule	Internal graticule; continuously adjustable illumination	

(7) Line power requirements

Item	Specification	Remarks
Voltage range	90 - 110 V, 104 - 125 V, 194 - 236 V, 207 - 250 V	Selectable by connector change
Frequency	50 Hz or 60 Hz	
Power consumption	Approx. 55 VA	

863741

(8) Mechanical specifications

Item	Specification	Remarks
Dimensions	288 W × 150 H × 370 D mm (11.37 W × 5.19 H × 14.57 D in.)	Mainframe
	340 W × 200 H × 440 D mm (13.39 W × 7.87 H × 17.32 D in.)	Maximum
Weight	Approx. 7.4 kg (16 lbs)	

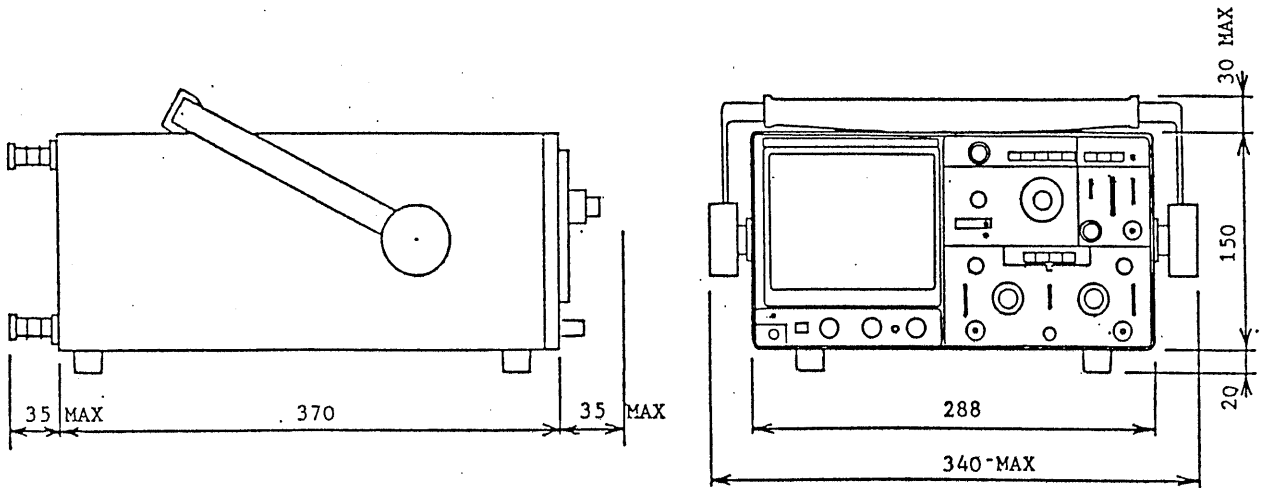

(9) Operating environment

To satisfy specifications: 5 to 35°C (41 to 95°F), 85% RH or less

Maximum operating ranges: 0 to 40°C (32 to 104°F), 90% RH or less

(10) Accessories

P060-S probes (10:1, 1:1, 1.5 m)	2
942A terminal adaptors	2
Power cord	1
Operation manual	1

o Specifications and contents on this manual are subject to change without notice.

863742

3. GENERAL PRECAUTIONS

o Environments

Avoid exposing the oscilloscope to unfavorable environments as follows:

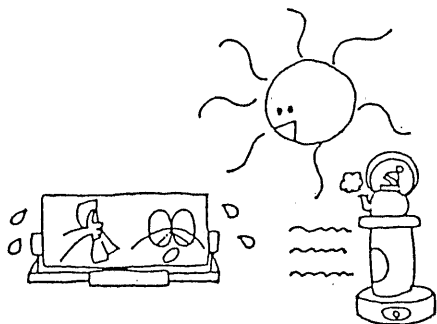

- o Direct sunlight or other hot place of 40°C (104°F) or over

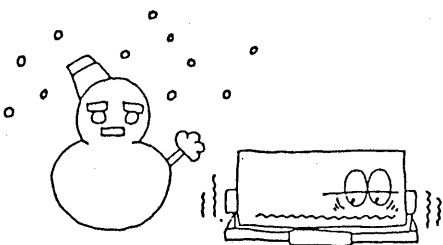

- o Rapid temperature change

- o Cold place of 0°C (32°F) or below

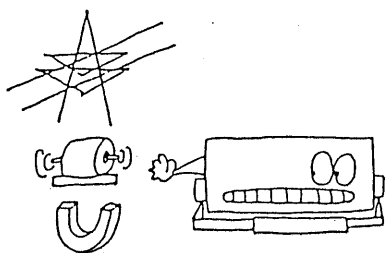

- o Strong magnetic or electric field

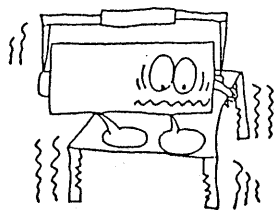

- o Unreasonably large mechanical vibration

o CRT intensity

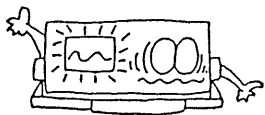

- o In order to prevent permanent damage to the CRT phosphor, do not make the CRT trace excessively bright or leave the spot stationary for an unreasonably long time.

o Unpacking the Oscilloscope

The oscilloscope is shipped from the factory after thoroughly inspected and tested. Upon receipt of the instrument, immediately unpack and inspect it for any damage which might have been sustained when in transportation. If any sign of damage is found, immediately notify the bearer and/or the dealer.

o Checking the Line Voltage

The oscilloscope can operate on any one of the line voltages shown in the below table, by inserting the line voltage selector plug in the corresponding position on the rear panel. Before connecting the power plug to an AC line outlet, be sure to check that the voltage selector plug is set in the correct position corresponding to the line voltage. Note that oscilloscope may not properly operate or may be damaged if it is connected to a wrong voltage AC line. When line voltages are changed, replace fuses also as required.

Selector plug position	Nominal voltage	Voltage tolerance	Fuse
A	100 V	90 - 110 V	1 A
B	115 V	104 - 125 V	
C	215 V	194 - 236 V	0.5 A
D	230 V	207 - 250 V	

o Resetting the Oscilloscope

When an erroneous operation (erroneous setting) of the oscilloscope is suspected, reset it by turning OFF power once and then turning it ON again. This will reset the oscilloscope (CPU) to the normal state. If it is not reset, contact your Kikusui agent for service.

86374A

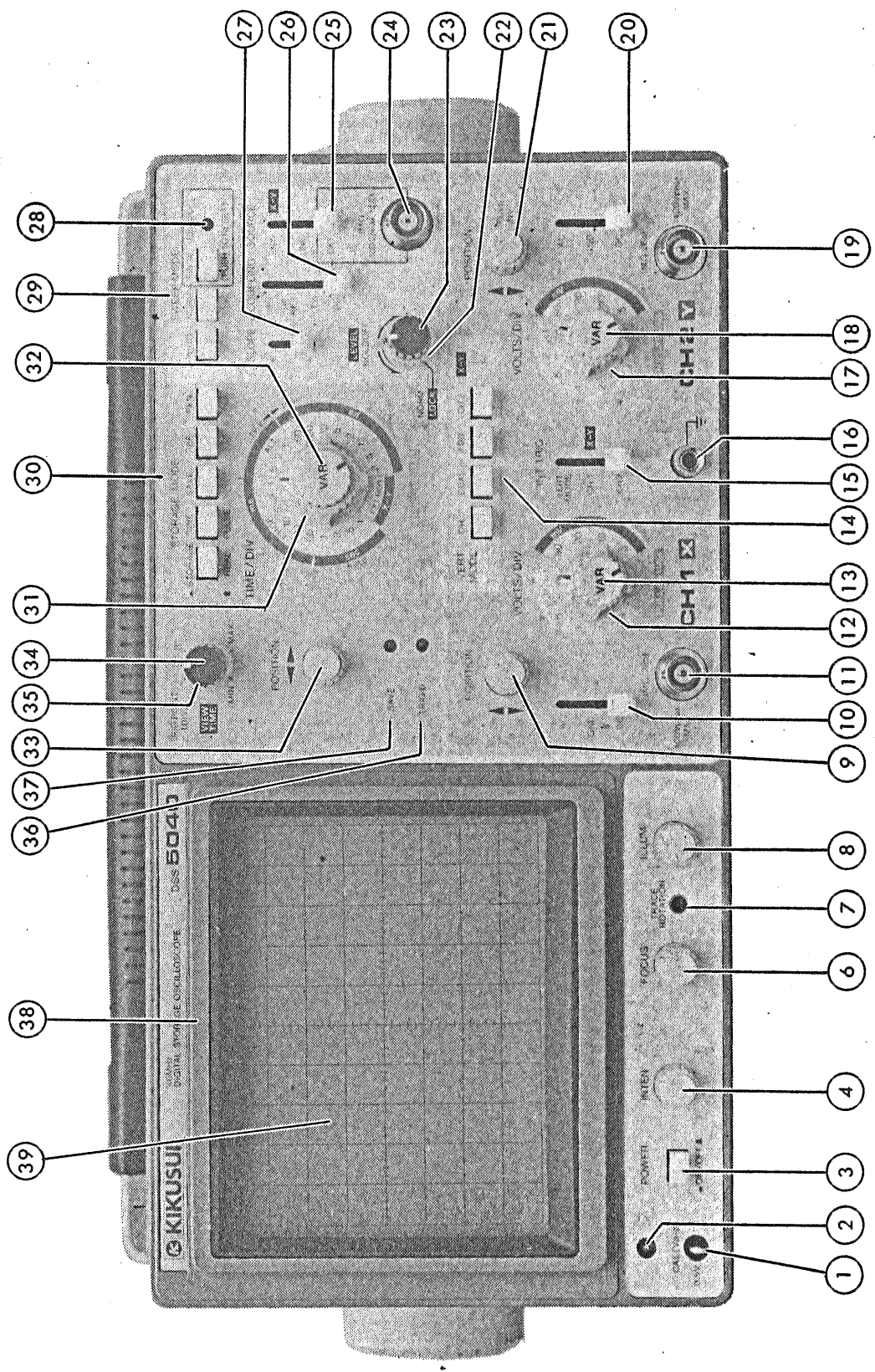

FRONT PANEL

4. DESCRIPTION OF PANELS

4.1 Description of Front Panel

- o Power Switch
- o CRT Controls
- o CAL Adjustments

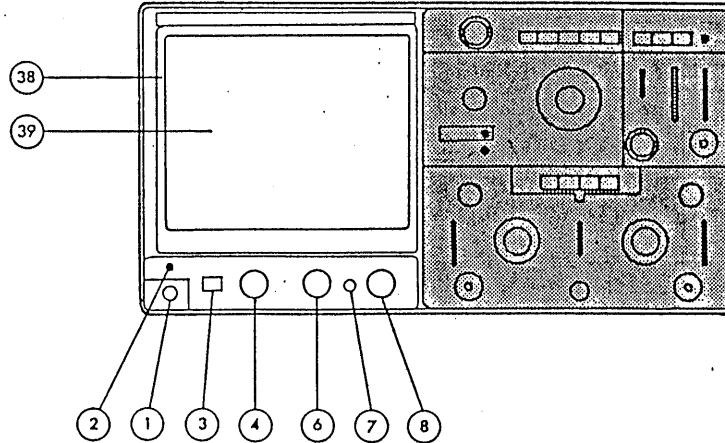

- CAL (V_{p-p}) ① This terminal delivers the calibration voltage of 2 V_{p-p}, approximately 1 kHz, positive square wave. The output resistance is approximately 2 kΩ.
- POWER ③ Main power switch of the instrument. When this switch is turned on, the LED ② above the switch also is turned on.
- INTEN ④ Controls the brightness of the spot or trace.
- FOCUS ⑥ For focusing the trace to the sharpest image.
- TRACE ROTATION ... ⑦ Potentiometer (driver adjustment type) for aligning the horizontal trace in parallel with graticule lines.
- ILLUM ⑧ Graticule illumination adjustment.

- Bezel (38) For installing a camera mount in one-touch operation.
- Filter (39) Filter for ease of waveform viewing. Can be removed in one-touch operation.

o Vertical Axes

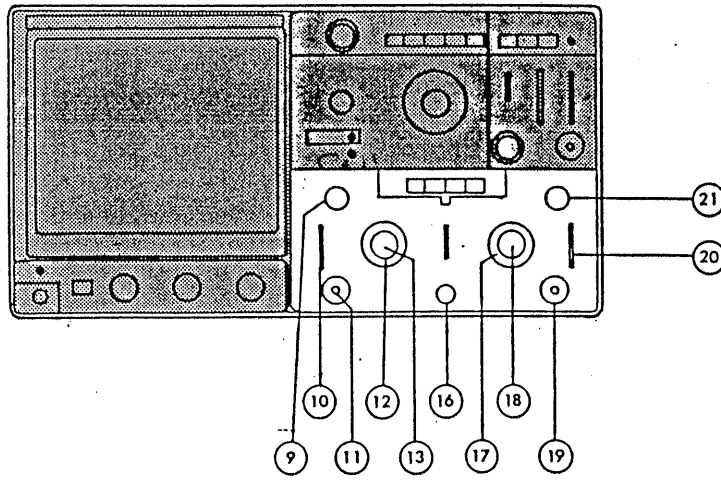

- CH1 (X) input (11) Vertical input terminal of CH1. During X-Y operation, this becomes X-axis (abscissa) input terminal.
- CH2 (Y) input (19) Vertical input terminal of CH2. During X-Y operation, this becomes Y-axis (ordinate) input terminal.
- AC-GND-DC (10)(20) Switch for selecting connection mode between input signal and vertical amplifier.

AC: AC coupling

GND: Vertical amplifier input is grounded and input terminals are made open.

DC: DC coupling

863747

VOLTS/DIV (12)(17) Select the vertical axis sensitivity, from 5 mV/DIV to 5 V/DIV with 10 ranges.

VARIABLE (13)(18) Fine adjustment of sensitivity, to VOLTS/DIV a factor of 1/2.5 or more of the panel-indicated value. At the CAL'D position, sensitivity is calibrated to the panel-indicated value. When this knob is pulled out ($\times 5$ MAG state), the amplifier sensitivity is multiplied by 5 times.

POSITION (9)(21) Vertical positioning control of trace or spot.

Ground terminal of oscilloscope mainframe.

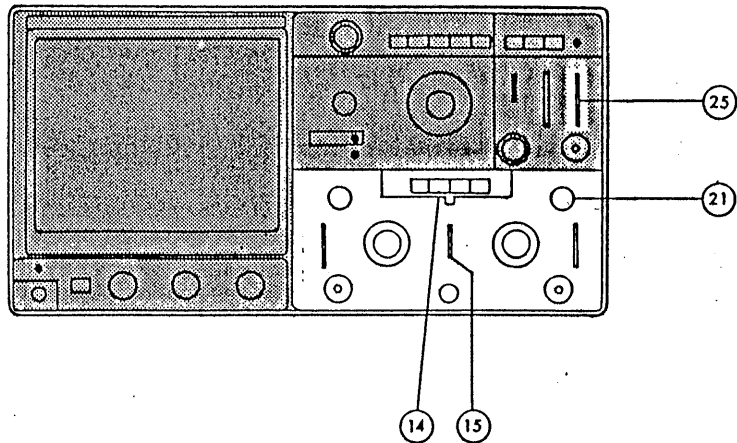

VERT MODE (14) Selects operation modes of CH1 and CH2 amplifiers. Also selects internal triggering source signal.

CH1: The oscilloscope operates as a single-channel instrument with CH1 alone.

CH2: The oscilloscope operates as a single-channel instrument with CH2 alone.

DUAL: The oscilloscope operates as a dual-channel instrument with both CH1 and CH2.
(CHOP or ALT mode)

ADD: The oscilloscope display the algebraic sum (CH1 + CH2) or difference (CH1 - CH2) of the two signals. The pulled out state of CH2 POSITION knob (21) provides the difference (CH1 - CH2). The internal triggering source signal is selected by SOURCE switch (15).

Note: If selection is changed for data saved in the storage mode, an error state is caused and the display blinks.

863749

INT TRIG

①5

Selects the internal trigger signal source. The signal selected by this switch is fed to the trigger circuit if SOURCE switch ②5 is set in the INT state.

CH1 (X-Y): The input signal of CH1 is used as the trigger signal and the signal is connected to the X axis during X-Y operation.

CH2: The input signal of CH2 is used as the trigger signal.

VERT MODE: The input signal which is displayed on the CRT screen is used as the trigger signal. When in this mode, triggering also is in an alternate mode and the signals of both CH1 and CH2 are alternately used for triggering respective channels. It is necessary to use trigger LEVEL ②1 to adjust the level for obtaining the best triggering.

863750

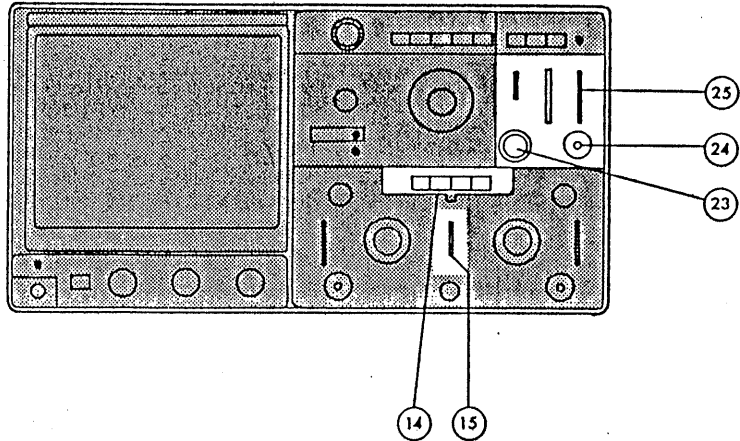

SOURCE (25) Selects the trigger signal.

INT (X-Y): Internal signal selected by INT TRIG switch (15) is used as the trigger signal and also connected signal when X-Y operation.

LINE: AC line signal is used as the trigger signal.

EXT: The input signal of EXT TRIG INPUT terminal (24) is used as the trigger signal.

EXT TRIG (EXT HOR) .. (24) This terminal is used in common for external triggering signal and external horizontal signal. To use this terminal, set SOURCE switch (25) to the EXT position.

863751

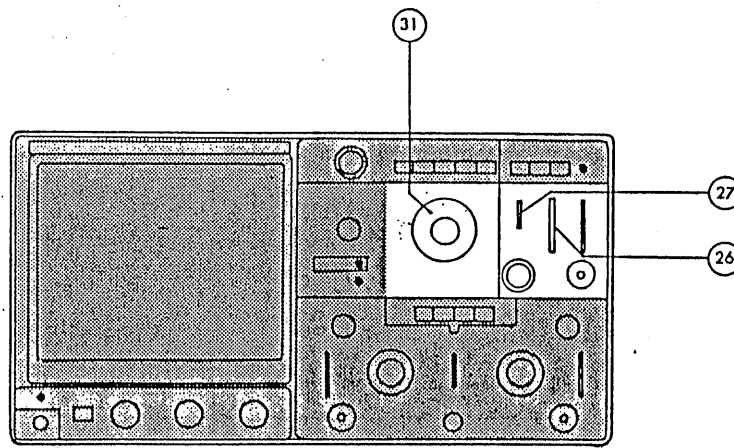

SLOPE (27) Selects the triggering slope.

"+": Triggering occurs when the triggering signal crosses the triggering level in the positive-going direction.

"-": Triggering occurs when the triggering signal crosses the triggering level in the negative-going direction.

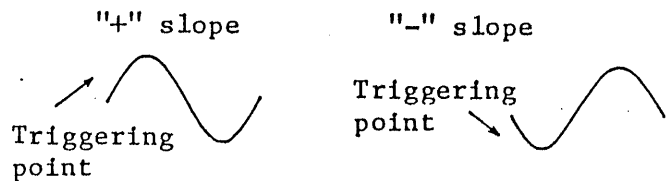

COUPLING (26) Selects coupling mode between triggering source signal and trigger circuit; selects connection of TV sync trigger circuit.

AC: AC coupling

HF REJ: AC coupling, with components higher than 50 kHz rejected.

TV: The trigger circuit is connected to the TV sync separator circuit and the sweeps are synchronized with the TV V or TV H signal at a rate selected by the TIME/DIV switch (31).

TV V: 0.5 sec/DIV - 0.1 msec/DIV.

TV H: 50 μ sec/DIV - 0.2 μ sec/DIV.

DC: DC coupling

863752

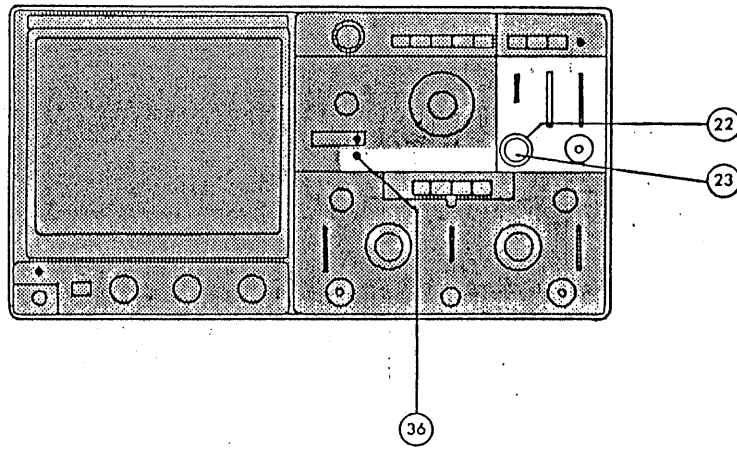

- HOLDOFF (22) These double-knob controls are for
 LEVEL (23) holdoff time adjustment and triggering
 level adjustment.

The HOLDOFF time control is used when the signal waveform is complex and stable triggering cannot be attained with LEVEL knob (23) alone.

The LEVEL knob is for displaying a synchronized stationary waveform and setting a start point for the waveform.

As this knob is turned in "+ +" direction, the triggering level moves upward on the displayed waveform; as the knob is turned in "- +", the triggering level moves downward.

When set at the LOCK position, the triggering level is automatically maintained at the optimum value irrespective of the signal amplitude (from very small amplitude to large amplitude), requiring no manual adjustment of triggering level.

When triggered, the lamp (36) illuminates.

863753

o Horizontal axis(time base)

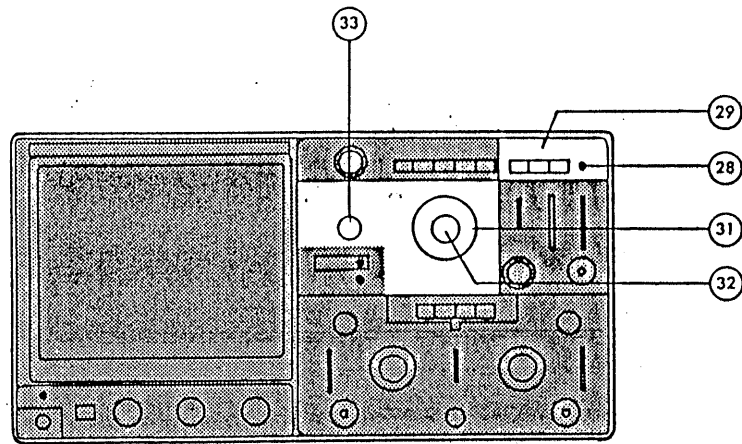

TIME/DIV (31)

Selects the sweep time. When this switch is set to the X-Y EXT HOR position, the oscilloscope operates as an X-Y scope with CH1 for the X-axis or operates in the EXT HOR mode with an external sweep input signal for the horizontal signal.

VARIABLE (32)

PULL $\times 10$ MAG

Vernier control of sweep time and $\times 10$ MAG switch. (This control remains idle when in the storage mode.) The sweep time can be made slower by a factor of 2.5 or more of the panel-indicated value.

The panel-indicated values are calibrated with this knob set in the CAL'D position.

The pulled out position of this knob is for the $\times 10$ MAG state.

POSITION (33) Vertical adjustment of the trace or spot.

863754

SWEEP MODE (29) Selects the desired sweep mode.

AUTO: When no triggering signal is applied or when triggering signal frequency is less than 50 Hz, sweep runs in the free run mode.

NORM: When no triggering signal is applied, sweep is in a ready state and the trace is blanked out. Used primarily for observation of signals of 50 Hz or lower.

SINGLE: Used for single sweep operation (one-shot sweep operation), and in common as the reset switch.

(PUSH
TO
RESET)

When the three buttons are in the pushed out state, the circuit is in the single sweep mode. The circuit is reset as this button is pressed. When the circuit is reset, the READY lamp (28) turns on. The lamp goes off when the single sweep operation is over.

863755

o Storage Mode

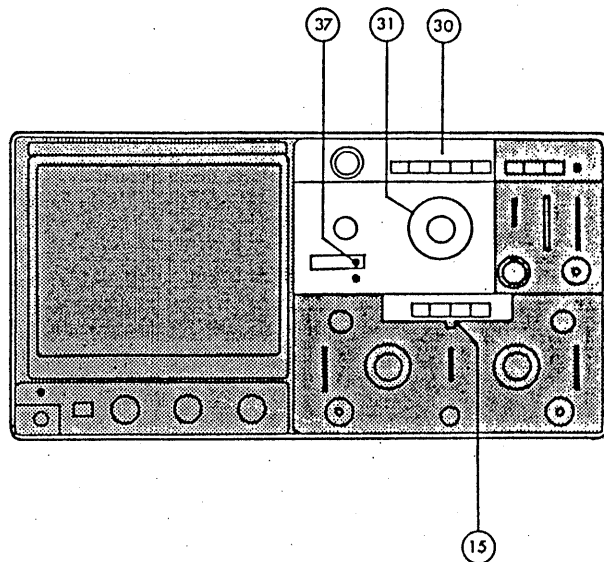

STORAGE MODE (30) These switches are for selection between storage mode and real mode, and for selection of the various functions in the storage mode.

STORE/NON-STORE:

The pushed-out state is for the real mode and the DSS5040 operates as a real time oscilloscope. The pushed-in state is for the storage mode and the DSS5040 operates as a digital storage oscilloscope.

SINE/PULSE:

To select an interpolation mode for data measured with ranges 50 $\mu\text{sec}/\text{DIV}$ - 0.2 $\mu\text{sec}/\text{DIV}$ of TIME/DIV switch (31). Effective also when saved data is magnified.

The pushed-out state is for pulse interpolation for viewing of linear waveforms such as pulse waves.

The pushed-in state is for sine interpolation.

This mode of interpolation is applicable to signal waveforms of up to approximately 7 MHz.

SAVE:

The displayed waveform is saved, storing of data is halted, and the SAVE lamp (37) turns on. The saved waveform can

190.8 24
863756A

be displayed being magnified up to 100 times by interpolation with the TIME/DIV switch (31).

Note: If the reproduced waveform is with a TIME/DIV range slower than that used for saving or faster than 100 times, the displayed waveform blinks to indicate the erroneous state. It blinks also if the VERT MODE switch (15) is changed when saving the waveform.

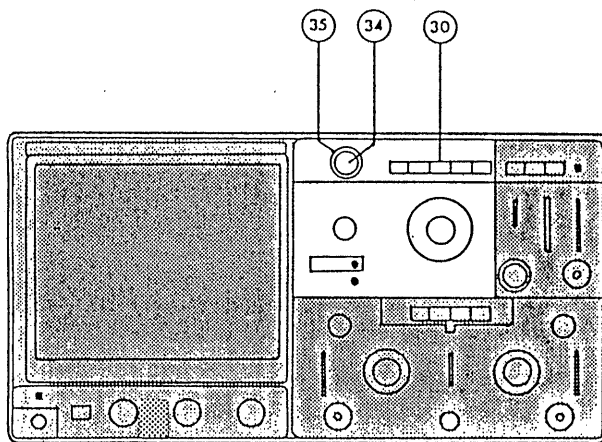

SAVE REF (30) :

If this button is pressed, the waveform displayed on the CRT at the moment is saved as reference and the data stored subsequently can be sequentially compared with the reference data.

STORE INTERVAL (34)

To adjust intervals of data storing. The counterclockwise extreme position is for continuous storing. As this control is turned clockwise, the storing interval is adjustable continuously-variably for a range of 0.5 sec to 5 sec.

TRIG POINT (DIV) (35)

To select a triggering point to view waveform which existed before the triggered point. Selectable for a range of 2, 5, or 8 DIV.

DISPLAY CENTER (5)

Due to terrestrial magnetism or other external cause, the display range on the CRT may not conform with the storage range and some parts of the displayed waveform may be clipped. In such a case, the overall waveform can be moved by this control so that the CRT display range conforms with the storage range. The overall waveform moves upward as this control is turned clockwise, and vice versa.

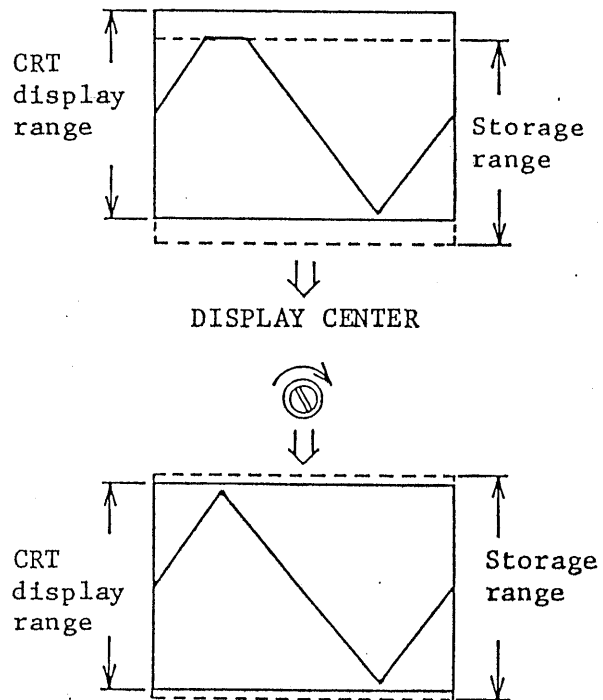

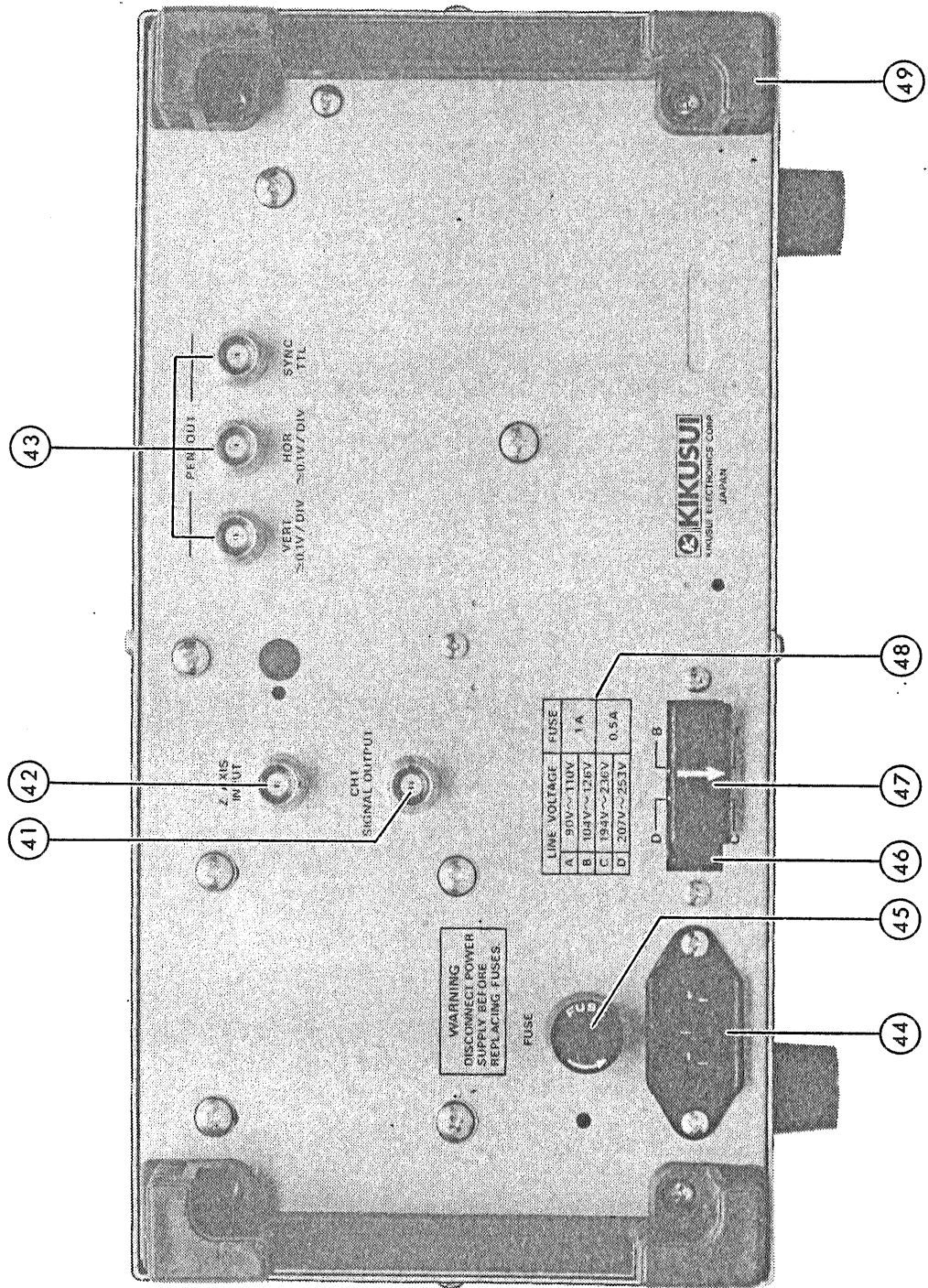

REAR PANEL

4.2 Description of Rear Panel

- o Z AXIS INPUT (42) Input terminals for external intensity modulation signal.

- o CH1 SIGNAL OUTPUT ... (41) Delivers the CH1 signal with a voltage of approximately 100 mV per 1 DIV of graticule. When terminated with 50 ohms, the signal is attenuated to about a half. May be used for frequency counting, etc.

- o PEN OUT (43) These output terminals deliver the vertical, horizontal, and synchronization signals when in PEN OUT mode.

- o AC Power Input Circuit
 - AC power input connector ... (44) Input connector of the AC power of the instrument. Connect the AC power cord (supplied) to this connector.

 - FUSE (45) Fuse in the primary circuit. Fuse rating is as shown in Table (48).

 - AC voltage selecting connector ... (46) For selecting the AC voltage of the instrument.

 - AC voltage selector plug ... (47) For selecting the AC voltage of the instrument by aligning its arrowhead mark in the corresponding position as shown in Table (48).

 - Studs (49) Studs for laying the oscilloscope in the vertical upward posture. Also used to take up the power cord.

863760

5. BASIC OPERATION METHOD

















5.1 AC Line Voltage Setting

Before connecting the power cord to an AC line outlet, check that the oscilloscope has been correctly set for the AC line voltage with the AC line voltage selector plug (47) on the rear panel of the oscilloscope. (Refer to 4.2 "Description of Rear Panel.")

5.2 To Display a Trace on the CRT



- 1) Set the switches and controls as shown in Table 5-1.

Table 5-1

Switch or Control			Setting
POWER	(3)		OFF position
INTEN	(4)		3-o'clock position
FOCUS	(6)		Mid-position
ILLUM	(8)		CCW position
VERT MODE	(14)		CH1
INT TRIG	(15)		VERT MODE
↓ POSITION	(9) (21)		Mid-position, pushed in
VOLTS/DIV	(12) (17)		10 mV/DIV
VARIABLE	(13) (18)		CAL'D (CW) position, pushed in
AC-GND-DC	(10) (20)		INT
SOURCE	(25)		AC
COUPLING	(26)		AC
SLOPE	(27)		+
LEVEL	(23)		LOCK (CCW)
HOLD OFF	(22)		NORM (CCW)
SWEEP MODE	(29)		AUTO
STORAGE/REAL	(30)		REAL

To be continued

863761

Switch or Control			Setting
TIME/DIV	(31)		0.5 ms/DIV
VARIABLE	(32)		CAL'D (CW) position, pushed in
↔ POSITION	(33)		Mid-position

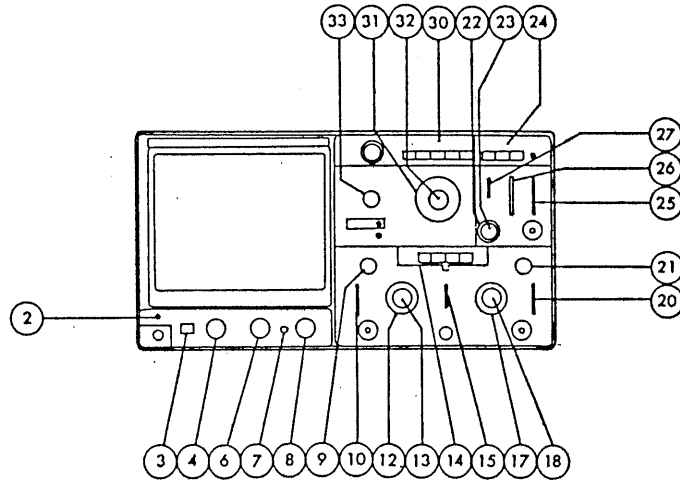

- 2) After setting the switches and controls as above, connect the power cord to the AC line outlet.
- 3) Turn on (push in) the POWER switch (3) and check that the power indicator lamp (LED) (2) at upper left of the power switch turns on. In about 20 seconds, a trace will appear on the CRT screen. If no trace appears even after about 60 seconds, repeat the switch and control settings shown in Table 5-1.
- 4) Adjust the trace to an appropriate brightness and to the sharpest image with the INTEN control (4) and FOCUS control (6).

863762

5.3 To Align the Trace with the Graticule Line

If the displayed trace is not aligned with the horizontal graticule line at the center of the graticule due to terrestrial magnetism or other cause, align the trace as follows:

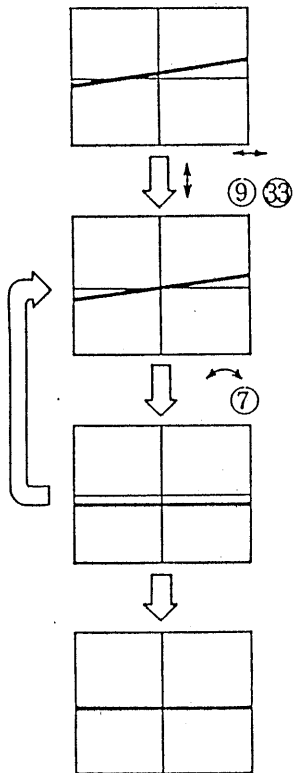

- 1) Connect the CH1 vertical input terminal to the GND terminal and display a horizontal trace. Assume that the trace is not aligned with the graticule line as illustrated.
- 2) Align the center of the trace with that of the graticule by adjusting the vertical POSITION control (9) and horizontal POSITION control (33).
- 3) Make the trace parallel with the horizontal graticule line by adjusting the TRACE ROTATION control (7) using a screwdriver.
- 4) If the trace is not aligned with the graticule line yet, repeat the procedures of 2) and 3) until the trace is precisely aligned.

Note: Be sure to check the above alignment each time the operating position (direction) of the oscilloscope is changed.

5.4 Calibration of Probe

The probe is a wide-range attenuator. Unless phase compensation is properly done, the displayed waveform is distorted causing measurement errors. Therefore, the probe must be properly calibrated before use. Calibration can be done by using the signal of the CAL (Vp-p) terminal ① of the front panel.

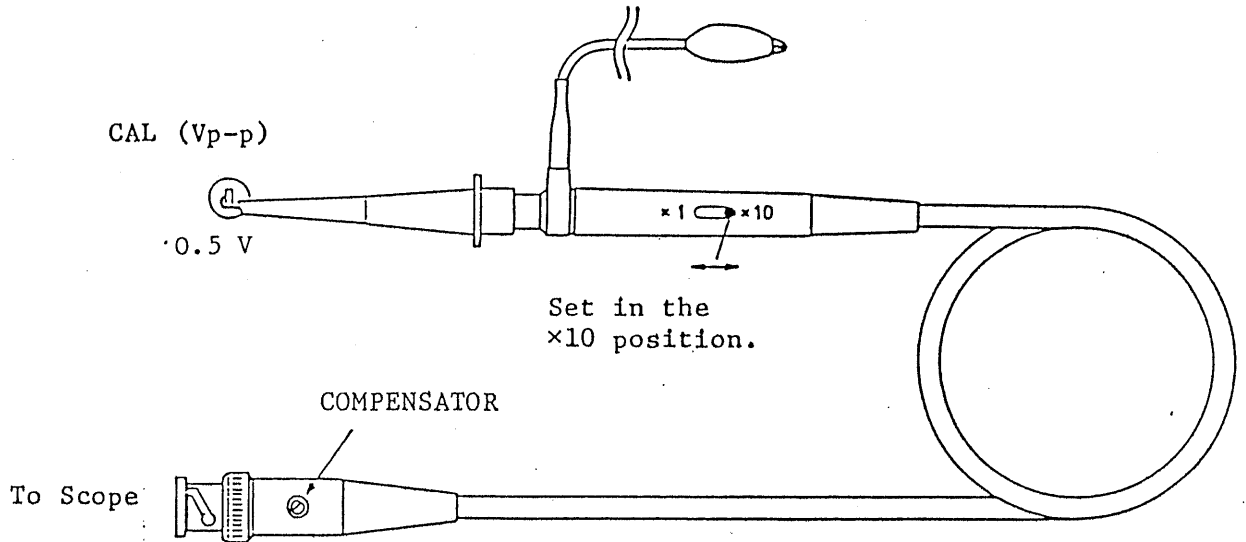

Connect the probe to the INPUT terminal of CH1 or CH2 and set VOLTS/DIV switch at 10 mV. Connect the probe tip to the calibration voltage output terminal and adjust the COMPENSATOR control with an insulated screwdriver so that an ideal waveform as illustrated below is obtained.

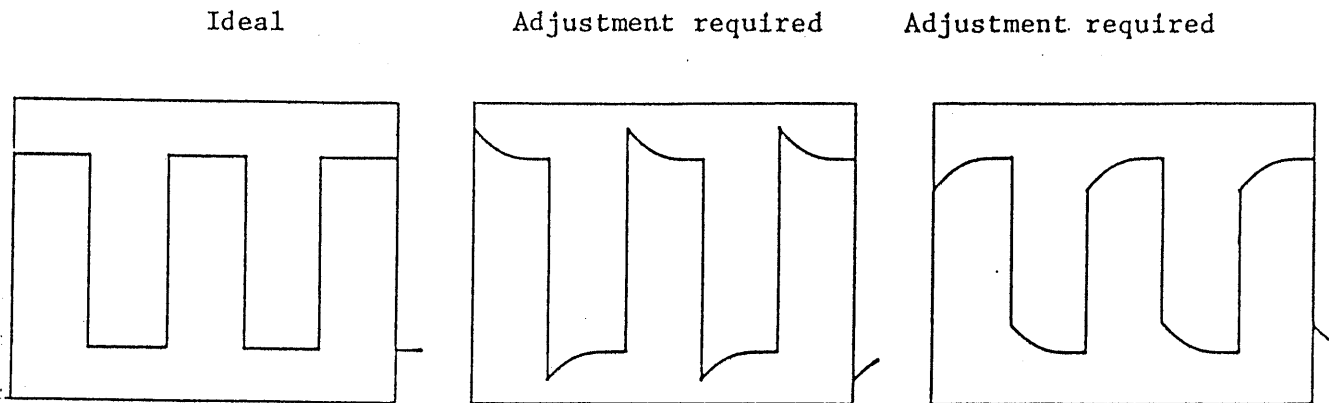

6. MEASUREMENTS OF WAVEFORM

6.1 Measurement in Real Mode

This section describes the operation method of the DSS5040 in the non-storage mode as a regular real-time oscilloscope.

1	Single-channel Operation
---	--------------------------

The operation method described hereunder is for single-channel measurement with CH1. Measurement with CH2 can be done by substituting CH1 by CH2 in the following description.

- 1) Set the switches and control as shown in Table 5-1.
- 2) Connect to the CH1 INPUT terminal (11) the accessory probe with its switch set to the $\times 10$ position. Apply to the probe the 2-volt calibration signal from the CAL (Vp-p) terminal (1).
- 3) Set the AC-GND-DC switch (10) to the AC position. A waveform as shown in Figure 6-1 will be displayed.

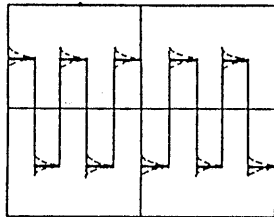





Figure 6-1

- 4) If the displayed waveform is not a pure pulse wave () as indicated with the solid line but is a distorted pulse wave ( or ) as indicated with a dotted line, calibrate the probe. (Refer to Section 5.4 "Calibration of Probe.")
- 5) Adjust the displayed waveform to the sharpest image with the FOCUS control (6).

863769

- 6) For regular waveform viewing, adjust the displayed waveform to an adequate amplitude and an adequate number of peaks (cycles) with the VOLTS/DIV switch (12) and TIME/DIV switch (31).
- 7) Align the displayed waveform with the graticule lines by adjusting the \updownarrow POSITION control (9) and the \leftrightarrow POSITION control (33), and determine the voltage (V_{p-p}) and period (T).

Note: Note that no sweep may be displayed if a DC signal which contains no AC components is measured with the SWEEP MODE selector (29) set in the NORM state because no triggering will occur in this case.

2	Dual-channel Operation
---	------------------------

- 1) Change the VERT MODE switch (14) to the DUAL position so that the other trace (CH2) also is displayed. (The trace explained in the preceding section was for CH1.) At this stage of procedure, the CH1 trace has the square wave of the calibration signal and the CH2 trace has a straight line since no signal is applied to this channel yet. See Figure 6-2.

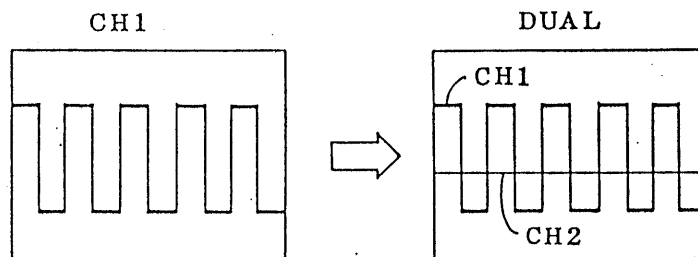

Figure 6-2

- 2) Apply the calibration signal also to the CH2 INPUT terminal (19) with the probe as is the case for CH1. Set the AC-GND-DC switch (20) to the AC position. Set the VOLTS/DIV switches (12) (17) to the 20 mV/DIV range and adjust the \updownarrow POSITION controls (9) (21) so that dual channels of waveforms are displayed as shown in Figure 6-3.

863766

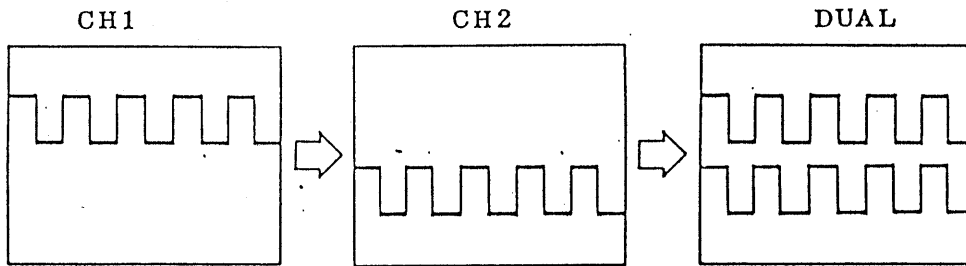

Figure 6-3.

- 3) When the oscilloscope is set for a dual channel mode (DUAL or ADD mode) and the SOURCE switch (25) is set for the INT mode, an internal triggering signal source(s) should be selected with the INT TRIG switch (15), which selects the source(s) as follows:

VERT MODE CH1 and CH2 (CH1 when in ADD mode)

CH1 CH1

CH2 CH2

When the signals of CH1 and CH2 are mutually synchronized, stationary waveforms of both signals can be displayed by selecting CH1 or CH2 for the triggering source. When the two signals are not in any synchronized relationship, select the VERT MODE and adjust the TRIG LEVEL control (23) so that stationary waveforms of both signals are displayed.

NOTES: Note that the VERT MODE is ineffective when in the CHOP mode (the CH1 signal is used as the triggering source signal). Also note that phase relationship will vary when two signal waveforms which are in a synchronized relationship are measured in the VERT MODE.

For details of triggering, refer to

5	Triggering
---	------------

 on Page 43.

863767

Note: Selection between CHOP mode and ALT mode is automatically made by the TIME/DIV switch (31). The 1 msec/DIV and lower ranges are used with the CHOP mode, and the 0.5 msec/DIV and higher ranges are used with the ALT mode.

CHOP mode for 1 msec/DIV and lower ranges:

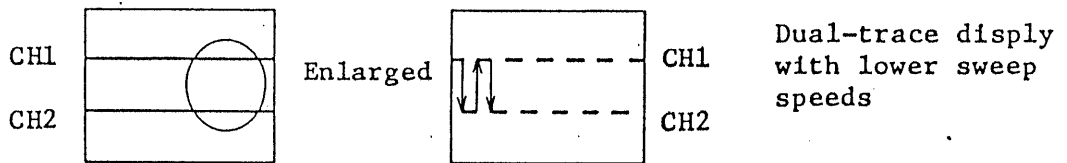

ALT mode for 0.5 msec/DIV and higher ranges:

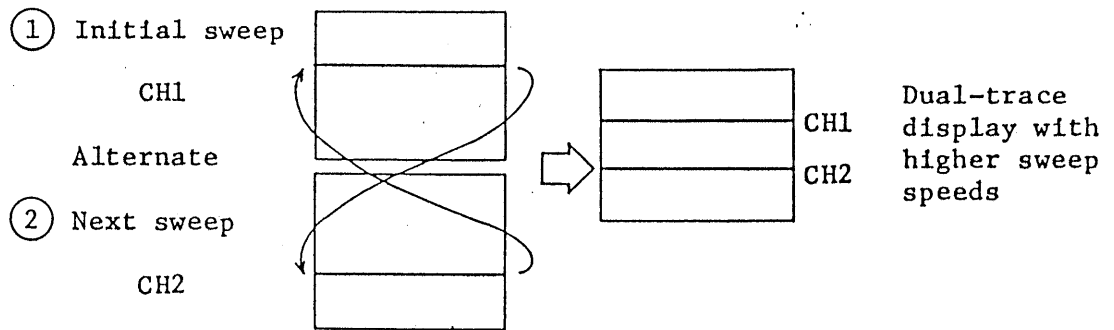

863768

3 To Add Two Waveforms

To display the sum of or difference between two waveforms, proceed as described in the following:

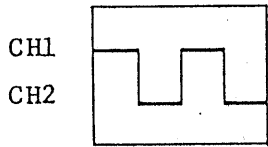

- o Before displaying the sum or the difference, adjust equal the sensitivities of CH1 and CH2 by applying the same input to both channels and adjusting the VARIABLE controls (13) and (18). This adjustment should be done in the center of the CRT from the viewpoint of linearity of the vertical amplifiers.

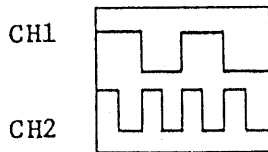

- o Algebraic sum:
Set the VERT MODE switch (14) to the ADD position. The sum of CH1 and CH2 signals will be displayed on the CRT.

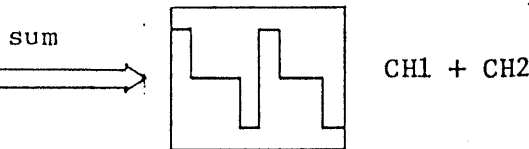

- o Algebraic difference:
1) Set the CH2 POSITION control (21) to the PULL INV state so that the CH2 signal is displayed being inverted.
2) Set the VERT MODE switch (14) to the ADD position. The difference between CH1 and CH2 signals will be displayed on the CRT.

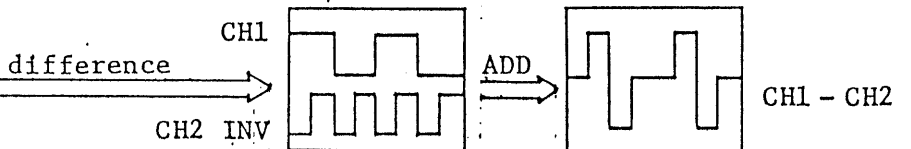

863769

4 To Use as an X-Y Scope

The DSS5040 can be operated as a single-channel or dual-channel X-Y scope as selected by the VERT MODE switch (14).

o Single-channel X-Y operation

- 1) Set the VERT MODE switch (14) to the CH2 X-Y position.
- 2) Set the INT TRIG switch (15) to the CH1 X-Y position.
- 3) Set the TIME/DIV switch (31) to the X-Y EXT HOR position. The DSS5040 will operate as X-Y scope.

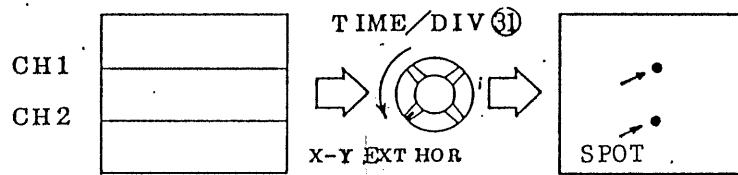

- 4) Select an X axis with the SOURCE switch (25). In this case, select a Y axis with the VERT MODE switch (14) (except CH2) as shown in the following table.

SOURCE (25)	X axis	VERT MODE (14)	Y axis
CH1 X-Y	CH1	CH2 X-Y	
LINE	LINE	CH1 or CH2	
EXT (external sweep)	EXT	CH1 or CH2	

- 5) When the above setting is done, the DSS5040 will operate as a single-channel X-Y scope. The CH1 POSITION control (9) becomes idle and the horizontal POSITION control (33) operates as an X-axis POSITION control. For the Y axes, CH1 and CH2 POSITION controls (9) and (21) remain effective.

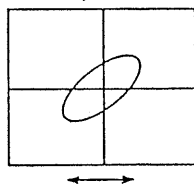

Y-axis: CH1 or CH2 POSITION controls (9) and (21)

X-axis: Horizontal POSITION control (33)

863770

o Dual-channel X-Y operation

- 1) Set the INT TRIG switch (15) to the CH1 X-Y position.
- 2) Set the VERT MODE switch (14) to the DUAL position. Then, set the TIME/DIV switch (31) to the

X-Y	EXT HOR
-----	---------

 position.

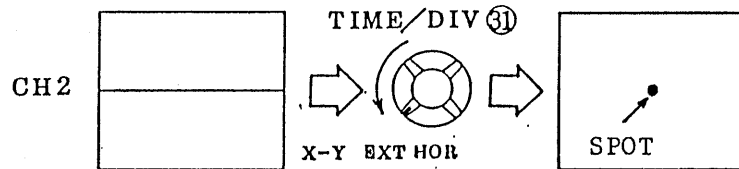

- 3) Select an X axis with the SOURCE switch (25) (except CH1 and CH2).

SOURCE (25)	X axis	Y axis
LINE	LINE	CH1 and CH2
EXT (external sweep)	EXT	CH1 and CH2

- 4) By the above setting, the DSS5040 operates as a dual-channel X-Y scope in the CHOP mode. The X axis is adjustable with the horizontal POSITION control (33) and the Y axes with the vertical CH1 and CH2 controls (9) and (21).

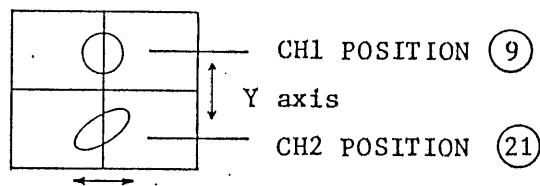

X axis: Horizontal POSITION (33)

o Frequency Bandwidths When in X-Y Mode

X axis: DC - 1 MHz (-3 dB)

Y axis: DC - 40 MHz (-3 dB)

When $\times 5$ MAG: DC - 20 MHz (-3 dB)

Note: Note that, when in the X-Y mode, the X-axis signal is subjected to AC, HF REJ, or DC coupling as selected by the TRIG COUPLING switch (26) as well as by the AC-GND-DC switches (10) and (20).

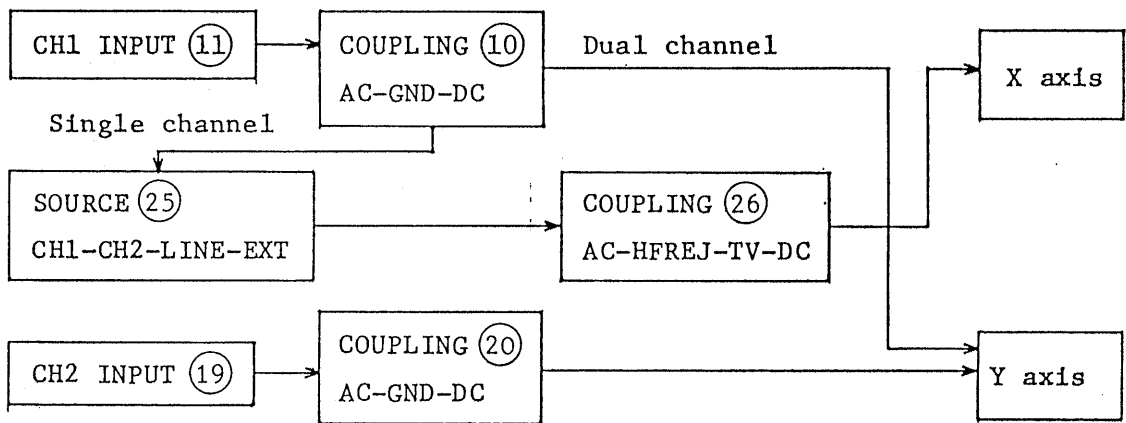

Block Diagram When in X-Y Mode

863772

5	Triggering
---	------------

Proper triggering is essential for efficient use of oscilloscopes. The DSS5040 has an internal trigger circuit for triggering with the input signal to be displayed or by the AC line signal and an external trigger circuit for triggering with an external signal which has a time relationship with the input signal to be displayed. Proper triggering methods are described in the subsequent paragraphs.

In general, the triggering procedure consists of the following four steps:

- 1) SOURCE (25) : Select a trigger source signal.
- ↓
- 2) COUPLING (26) : Select a coupling mode.
- ↓
- 3) SLOPE (27) : Select a triggering slope.
- ↓
- 4) LEVEL (23) : Adjust the triggering level.

1) Functions of SOURCE Switch (25)

To display a stationary pattern on the CRT screen, the displayed signal itself or a trigger signal which has a time relationship with the displayed signal is required to be applied to the trigger circuit. The SOURCE switch (25) selects such a triggering source.

863773

o Internal Trigger

INT: This internal triggering method is used most commonly as triggering can be readily accomplished with the internal signal(s) which is selectable with the INT TRIG switch as follows:

CH1: The CH1 signal is used as the triggering source signal. If there is a synchronized relationship between CH1 and CH2 signals, stationary waveforms of both signals are displayed.











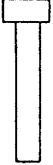

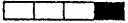
CH2: The CH2 signal is used as the triggering source signal. If there is a synchronized relationship between CH2 and CH1 signals, stationary waveforms of both signals are displayed.

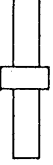
VERT MODE:

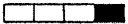
- o When in the SINGLE SWEEP mode with CH1 or CH2, the signal selected by the VERT MODE switch (14) is used as the triggering source signal.
- o When in the ALT mode, the CH1 and CH2 signals are alternately used as triggering source signals. Therefore, this mode is not suitable for measurement of phase differences between the two signals. When in the CHOP mode, the CH1 signal is used as the triggering source signal.
- o When in the ADD mode, the CH1 signal is used as the triggering source signal.

The above functions are tabulated in the following chart.

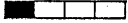
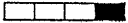
863774

SOURCE ②⑤	INT TRIG ①⑤	VERT MODE ①④	Triggering Source Signal
INT 	VERT MODE 	CH 1  CH 2  DUAL  ADD 	CH 1 CH 2 When ALT ... CH 1 and CH 2 alternately When CHOP ... CH 1 CH 1
	CH 1 	CH 1  CH 2  DUAL  ADD 	When ALT } CH 1 When CHOP }
	CH 2 	CH 1  CH 2  DUAL  ADD 	When ALT } CH 2 When CHOP }

Internal triggering source select

863773

LINE: The AC line frequency signal is used for triggering. This triggering is effective when the measured signal has a time relationship with the AC line frequency, especially for measurement of low level noise of audio equipment, etc.

o External Trigger

EXT: The sweep is triggered with an external signal applied to the external trigger input terminal (24). An external signal which has a periodic relationship with respect to the measured signal is used. Since the measured signal is not used as the triggering signal, waveform can be displayed more independently of the measured signal.

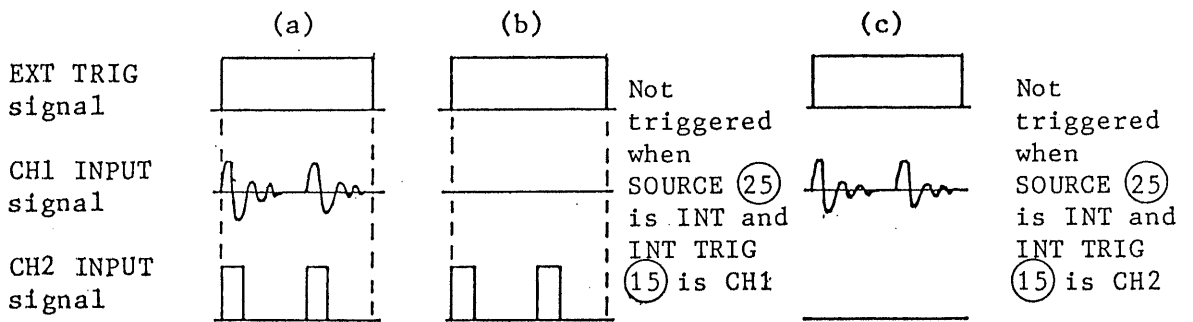

When CH1 and CH2 input signals vary:

In the case of (a), triggering is effected with the SOURCE switch (25) set to CH1 or CH2. In the case of (b) or (c), no triggering is effected with the SOURCE switch (25) set to INT and, therefore, an external trigger signal should be used.

863776

2) Functions of COUPLING Switch (26)

This switch selects the AC, HF REJ, TV, or DC coupling mode for the triggering signal fed to the trigger circuit.

AC: The DC and very low frequency components (lower than 10 Hz) of the triggering signal are cut off, thereby making triggering operation stable. This coupling mode is used most commonly.

HF REJ: The higher frequency components of the triggering signal are cut off. The triggering signal is fed to the trigger circuit via an AC-coupling circuit and a low-pass filter (50 kHz, -3 dB).

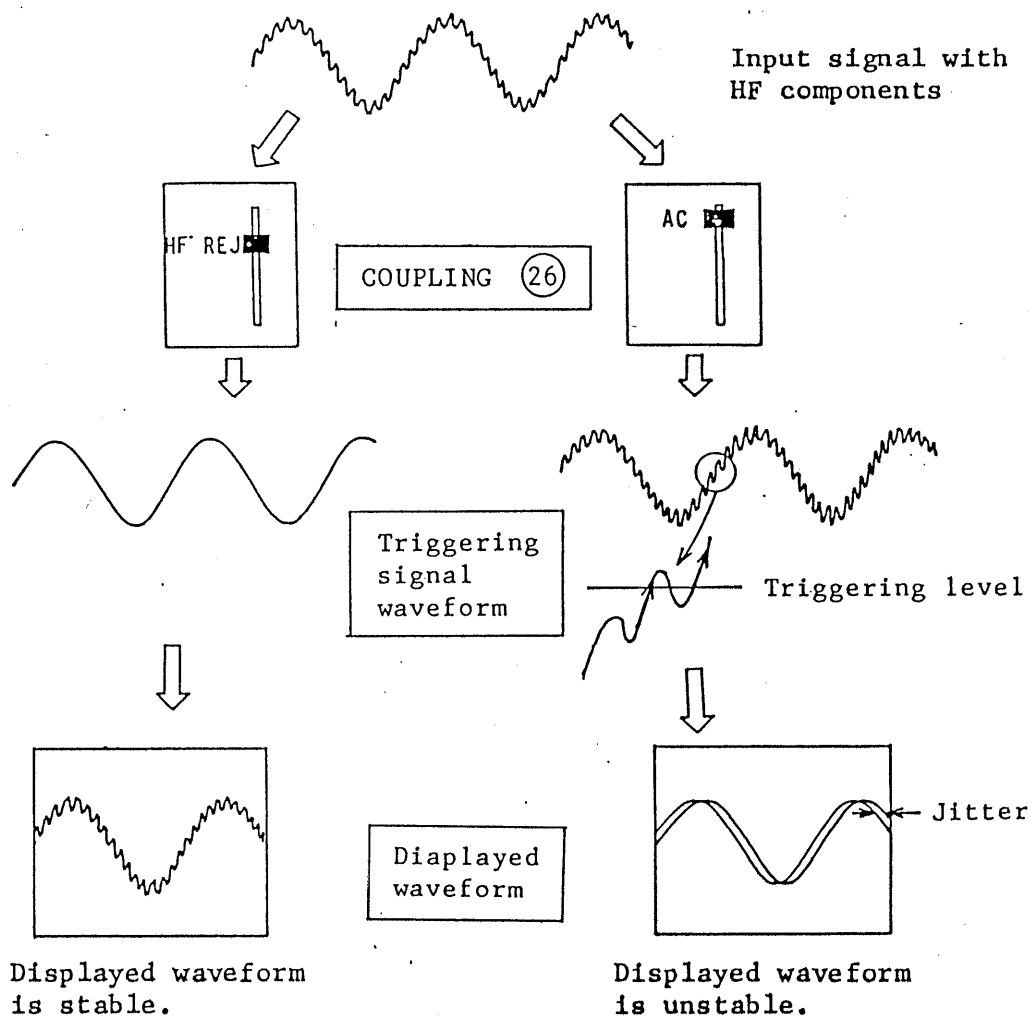

863777

TV: This coupling is used for TV triggering for observation of TV video signals. The triggering signal is AC-coupled and fed via the trigger circuit (level circuit) to the TV sync separator circuit. The separator circuit picks off the sync signal, which is used to trigger the sweep. Thus, the video signal can be displayed very stably.

Being linked to the TIME/DIV switch, the sweep speed is switched for TV.V and TV.H as follows:

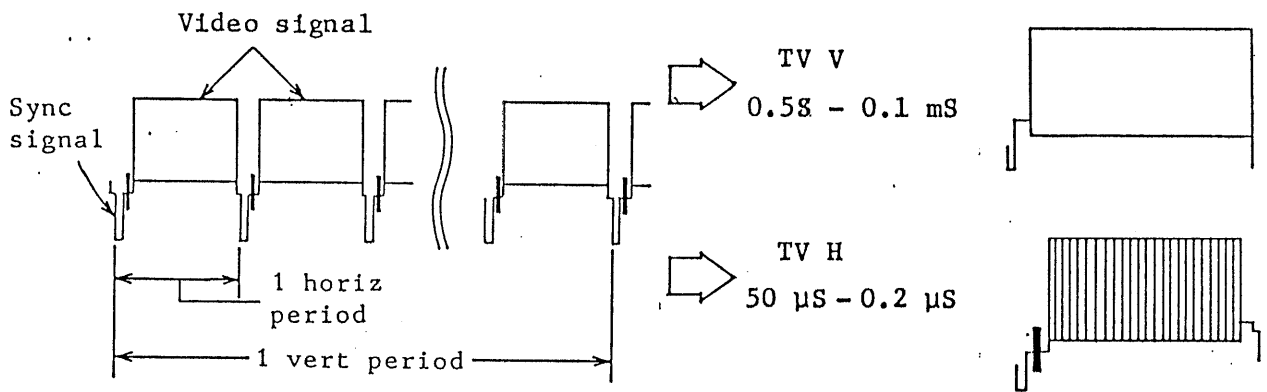

The SLOPE switch (27) should be set in conformity with the video signal as follows:

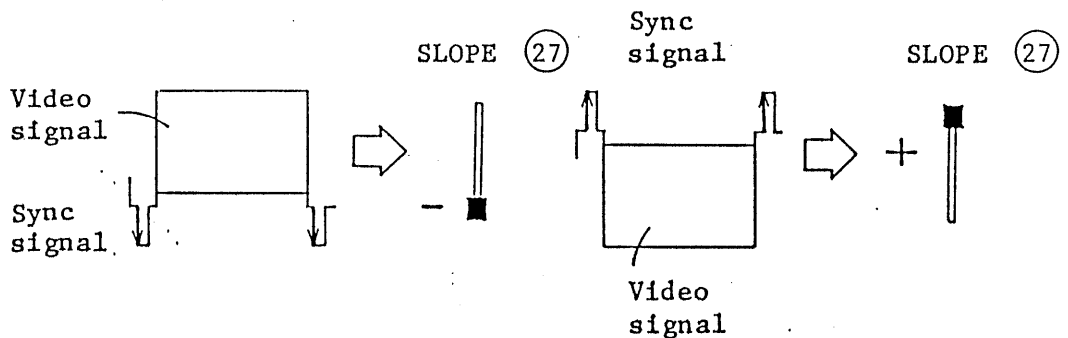

DC: The triggering signal is DC-coupled to the trigger circuit. This mode is used when triggering by the DC component of the triggering signal is desired or when a very low frequency signal or a signal of large duty cycle ratio is needed to be displayed.

863778

3) Functions of SLOPE Switch (27) :

This switch selects a slope (polarity) for triggering.

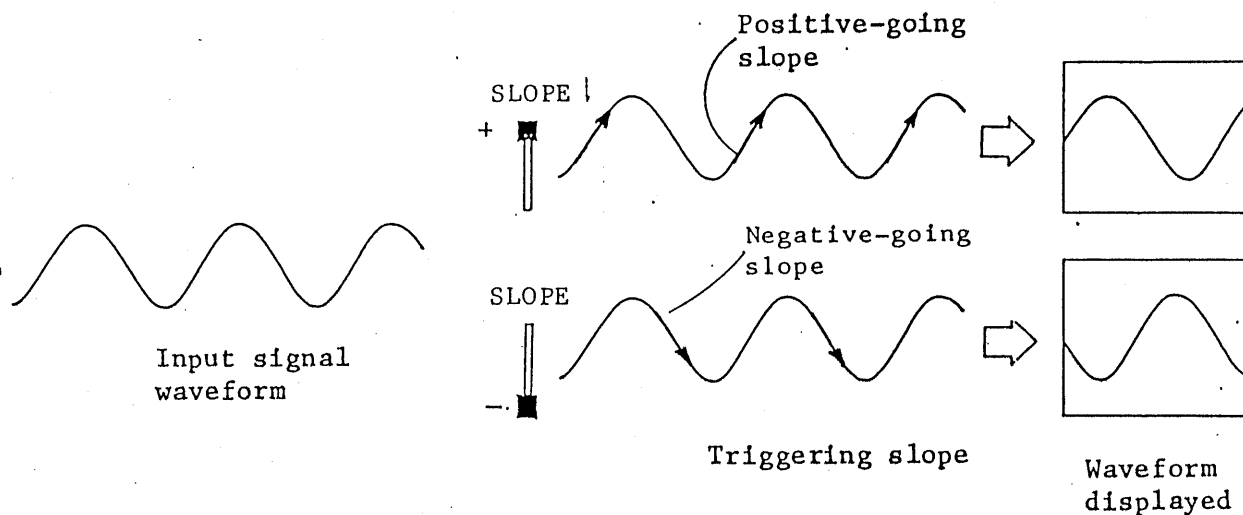

4) Functions of LEVEL (LOCK) control (23) :

This control is used to adjust the triggering level for stable display of waveforms. When this control is set in the LOCK position (counterclockwise extreme position), stable triggering is automatically realized within the following ranges (for signals of duty cycle not greater than 80:20):

50 Hz - 10 MHz: 1.0 DIV or less (0.15 V or less when in EXT mode)

50 Hz - 40 MHz: 2.0 DIV or less (0.25 V or less when in EXT mode)

o Triggering Level

The sweep circuit is triggered when the triggering signal has crossed the triggering level, to display a stationary waveform on the CRT.

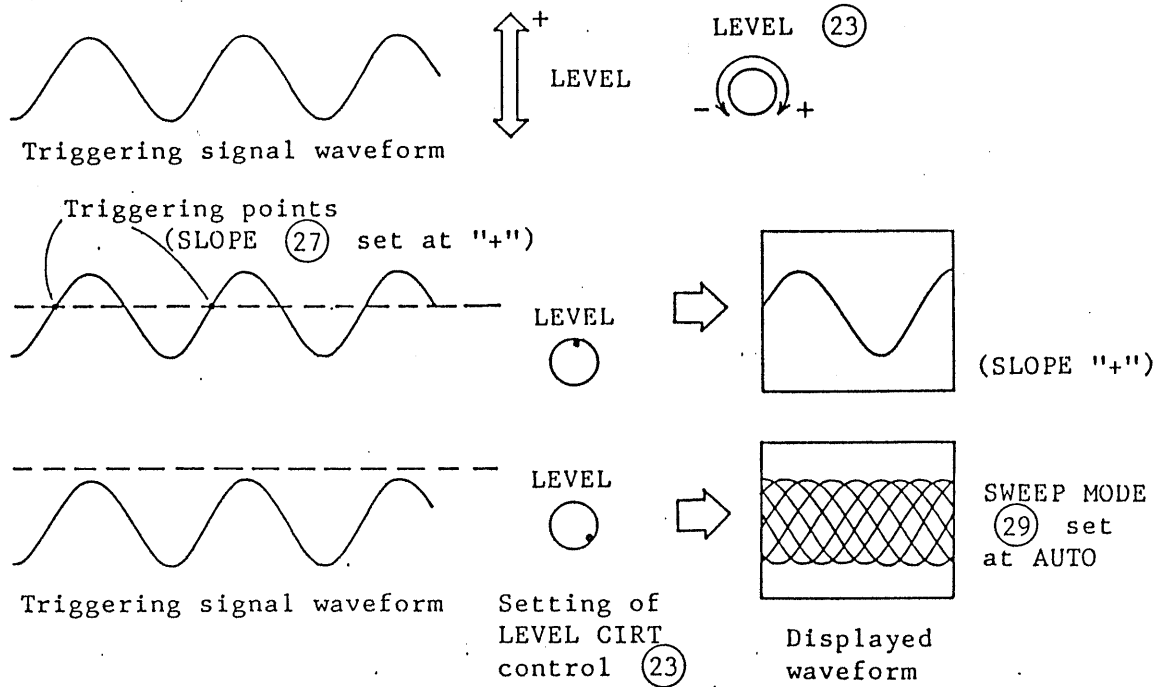

o Level Lock Function

When the LEVEL control (23) is set at the LOCK position, the triggering level is automatically set at a center between peaks of the input signal waveform and no manual level adjustment is needed.

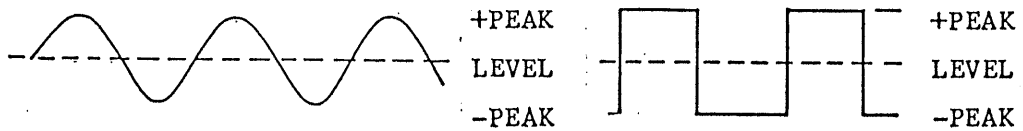

Triggering Input Signal and Triggering Level
When in LEVEL LOCK Mode

863780

o Level Adjustment of Complicated Waveforms

When the signal waveform is complicated as shown in the below example, two or more triggering points may result and the displayed waveform may be with two or more patterns overlapped. If such is the case, adjust the LEVEL control (23) so that only one triggering point is selected.

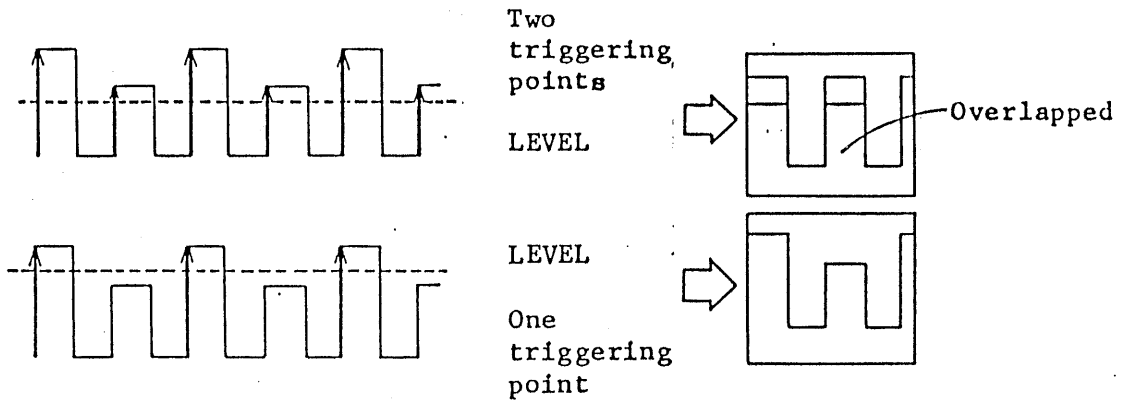

5) Functions of HOLD OFF control (22) :

When the measured signal has a complex waveform with two or more repetition frequencies (periods), triggering with the LEVEL control (23) alone may not be sufficient for attaining a stable waveform display. In such a case, the sweep can be stably synchronized to the measured signal waveform by adjusting the HOLD OFF time (sweep pause time) of the sweep waveform by means of the HOLD OFF control (22).

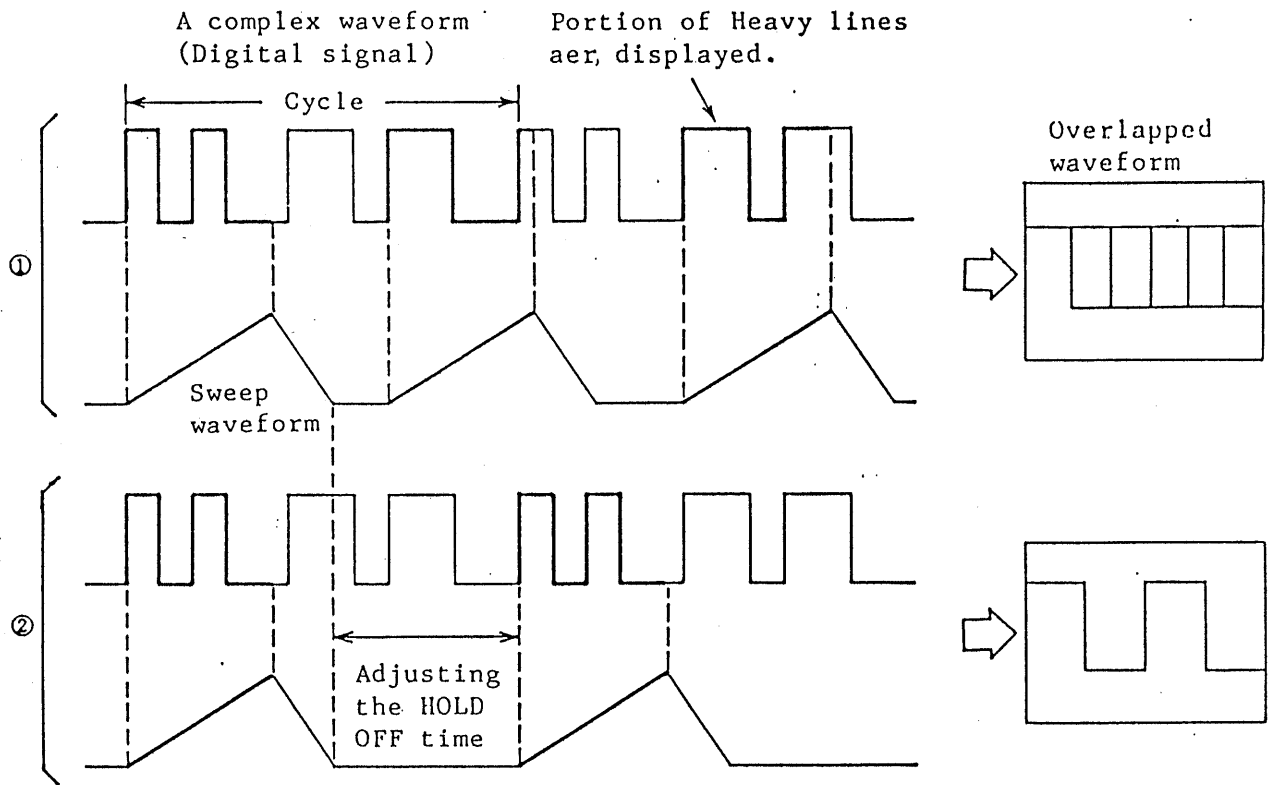

① shows a case for HOLD OFF knob at the NORM position. Various different waveforms are overlapped on the CRT screen, making the signal observation unsuccessful.

② shows a case in which the undesirable portion of the signal is held off. The waveform is displayed on the CRT screen without overlapping.

863782

The single-sweep operation is effective for measurement of the following types of signals:

- o A signal whose amplitude or period varies at random and cannot be displayed as a stationary waveform.
- o A signal of one-shot event

The single-sweep waveform may be photographed for viewing and analysis.

Note: Note, when taking photographs of the waveforms, that CH1 and CH2 are alternately swept if the oscilloscope is operating in the dual-channel single-sweep mode and the TIME/DIV switch (31) is set at 0.5 msec or slower.

o Measurement of Non-repetitive Signal

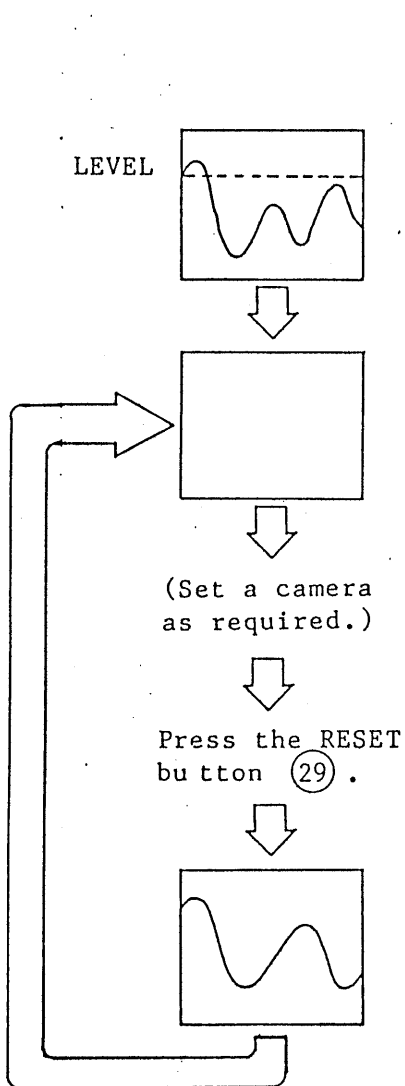

- 1) Set the SWEEP MODE switch (29) to the NORM position.
- 2) Apply the signal to be measured to the vertical input terminal (11) or (19). Adjust the triggering level with the LEVEL control (23).
- 3) Set the SWEEP MODE selector (29) in the SINGLE state (all of the three buttons are pushed out). The CRT screen will be blanked out.
- 4) Each time as you press the RESET button (29) (which is used also as the SINGLE button), the sweep runs only once and a waveform without overlapping is displayed and then the oscilloscope is reset to the state of 3).

o Measurement of One-shot Signal

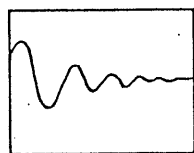

Anticipated one-shot signal



- 1) If the amplitude and period of the signal to be measured are predictable, set the oscilloscope accordingly.
- 2) Set the SWEEP MODE selector (29) to the NORM state.

863784

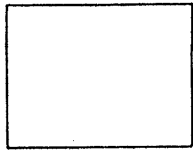
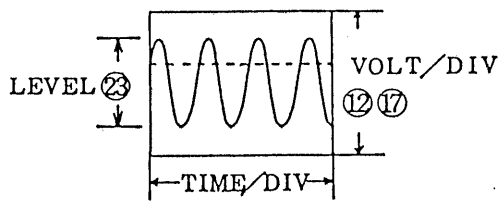

Set a camera as required.



Connect a signal to be measured.



Press the RESET button.

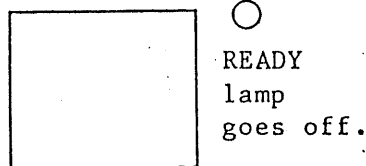
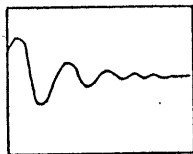
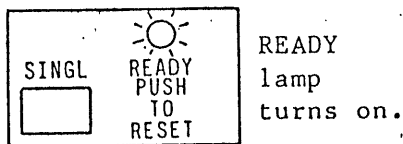

- 3) Apply a signal which is similar vertical input terminal (11) or (19), and set accordingly the VOLTS/DIV switch (12) or (17), TIME/DIV switch (31) and LEVEL control (23).
- 4) Set the SWEEP MODE selector (29) to the SINGLE state (all of the three buttons are pushed out).
- 5) Connect the measured signal to the vertical input terminal (11) or (19); using the probe or other means.
- 6) Press the RESET button (29) (which is used also as the SINGLE button) so that the sweep circuit becomes the ready state and the READY lamp (28) turns on.
- 7) As the signal to be measured is applied (as the phenomenon to be analyzed takes place), the sweep runs only once and then the READY lamp (28) goes off.
- 8) To repeat the viewing, repeat from step 6).

863785

7	Sweep Magnification
---	---------------------

When a certain position of the displayed waveform is needed to be expanded timewise, a faster sweep speed may be used. However, if the required portion is far away from the starting point of the sweep, the required portion may run off the CRT screen. In such a case, pull out (set in the $\times 10$ MAG state) the sweep VARIABLE knob (32). When this is done, the displayed waveform is expanded by 10 times to right or left with the center of screen as the center of expansion.

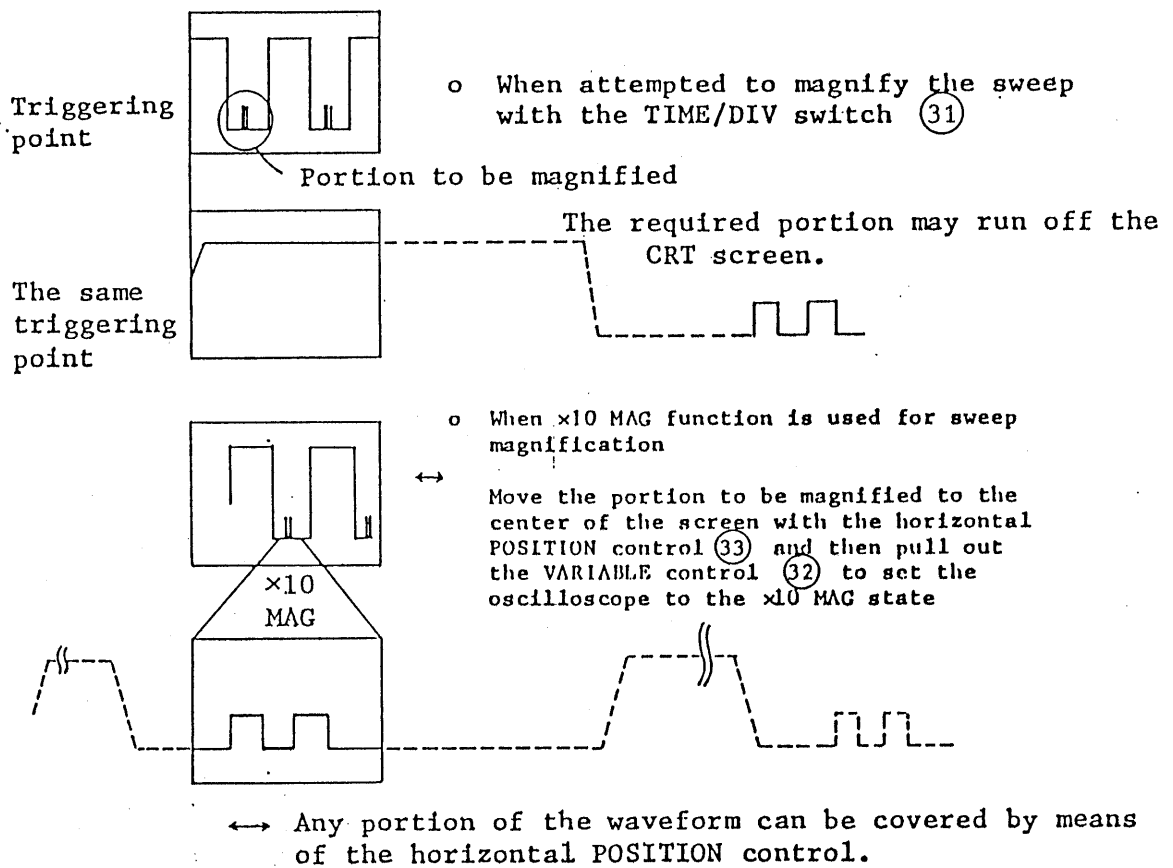

863786

The sweep time during the magnification operation is obtained as follows:

$$(\text{Value indicated by TIME/DIV switch}) \times 1/10$$

Thus, the unmagnified maximum sweep speed (0.2 $\mu\text{sec/DIV}$) can be made faster with magnification as follows:

$$0.2 \mu\text{sec/DIV} \times 1/10 = 20 \text{ nsec/DIV}$$

6.2 Measurement in Storage Mode

This chapter describes the operation methods of the DSS5040 as a digital storage oscilloscope, comparing its performances with those of storage-CRT oscilloscopes as cases may call for. The basic operation methods of the DSS5040 are identical for both storage use and real use.

Before operating the oscilloscope in the storage mode, make yourself thoroughly familiar with its operation in the real mode referring to the preceding chapter.

Notes for Operation in the Storage Mode

1) Items to be noted when switched over to the storage mode:

Note that no signal data can be acquired and measured in the below-mentioned cases. In such cases, observe the instructions given there for individual cases.

- o The SAVE switch (30) is in the ON () state:

Set it to the OFF () state.

- o The SWEEP MODE selector (29) is set in the NORM state and no triggering is effected:

Turn the LEVEL control (23) to the LOCK position (counter-clockwise extreme position) or adjust it so that triggering is effected. If triggering cannot be successfully effected, check the amplitude and other factors of the signal by setting the SWEEP MODE selector (29) to the AUTO state.

- o None of the modes are selected by the SWEEP MODE selector (29) :

Select the AUTO or NORM mode with the SWEEP MODE selector (29) .



The above are applicable also when the POWER switch (3) is turned on with the oscilloscope set in the storage mode.

2) Items to be noted when in operation:

- o If a waveform which has been saved with the TIME/DIV switch (31) set at a range lower than 2 μ sec is displayed with the TIME/DIV switch (31) set at a range slower than that with which the waveform has been saved, the displayed waveform blinks to indicate that the displayed waveform is invalid. A similar alarm indication occurs also when a waveform which has been saved with a range higher than 1 μ sec is displayed with the TIME/DIV switch (31) set at a range lower than 5 μ sec.
- o When in the storage mode, the time base VARIABLE control (32), HOLD OFF control (22), and the X-Y function remain idle.
- o No waveform backup is done when operation is changed from the storage mode to the real mode or when the POWER switch (3) is turned off.

1	Waveform Measurement in Storage Mode
---	--------------------------------------

- 1) To measure waveforms in the storage mode, set at first the switches and controls as follows:

Switch or Control		Setting
STORAGE MODE (30)		
STORAGE/REAL	<input type="checkbox"/>	REAL
SINE/PULSE	<input type="checkbox"/>	PULSE interpolation
SAVE	<input type="checkbox"/>	OFF
REF	<input type="checkbox"/>	OFF
TRIG POINT (35)		2-DIV position
VIEW TIME (34)		MIN (counterclockwise)

86378R

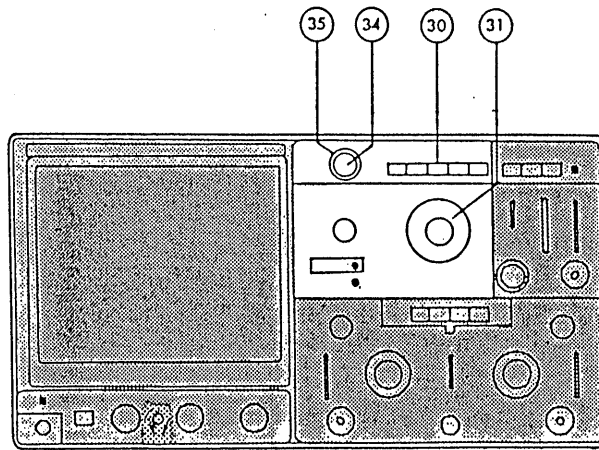

- 2) In the real mode, display the waveform to be measured.
- 3) Change the STORAGE/REAL switch (30) to the STORAGE (□) state.
The waveform will be digitally stored and displayed continuously.

Of the DSS5040, operation is automatically changed to the interpolation mode when the sweep speed is $1 \mu\text{sec}$ or faster and automatically changed to the roll mode when the sweep speed is slower than 0.1 sec. Data acquisition speed also is automatically changed by the TIME/DIV switch (31).

5005 196 8 24

863789A

☆ Interpolation

Interpolation is a function of estimating a value between two measured data values of a waveform. The DSS5040 is able to render pulse interpolation and sine interpolation.

o Pulse Interpolation

Pulse interpolation is referred to also as linear interpolation since a value between two known values is estimated employing a linear function. By magnifying the waveform with this interpolation, perceptual aliasing can be prevented. This interpolation facilitates measurement of waveform which is located apart by one sample point.

When a sine wave signal is measured and the number of sample points per one input signal cycle is less than 10, envelope errors as shown in Figure 6-2 are introduced. In such a case, sine interpolation should be used.

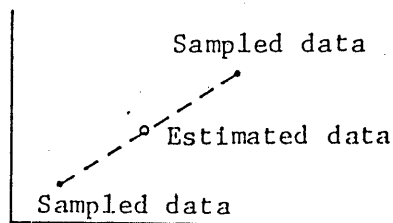

Figure 6-1. Pulse Interpolation

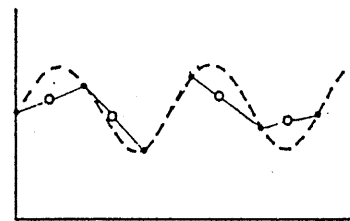

Figure 6-2. Envelope Errors of Pulse Interpolation

o Sine Interpolation

Since interpolation is effectively applicable to most of the waveforms so far as their frequency is higher than $1/3.5$ of the sampling frequency. The DSS5040, whose maximum sampling frequency is 1 MHz, is able to render effective sine interpolation up to the following frequency for a sine wave which has a single spectrum only.

$$25 \text{ MHz} \times 1/3.5 \approx 7 \text{ MHz}$$

1988-1990 8.24

813790A

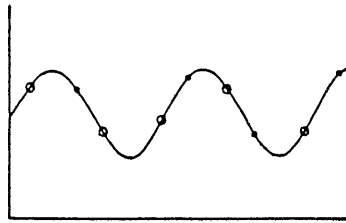

Figure 6-3. Sine Interpolation

o To Select Type of Interpolation

Either pulse interpolation or sine interpolation should be selected depending on whether the input signal waveform involves frequencies higher than $1/3.5$ of the sampling frequency or not. If a square wave, which involves much harmonics, is sine-interpolated, overshoots may result. If a sine wave is pulse-interpolated on the other hand, envelope errors as shown in Figure 6-2 may result. Therefore, use sine interpolation for sinusoidal waves and pulse interpolation for waves distorted with harmonics.

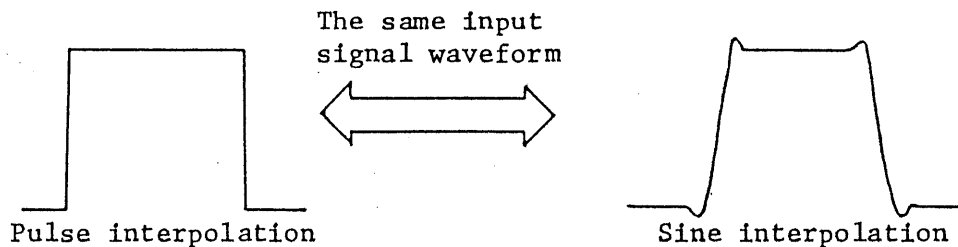

Figure 6-4

Note, however, that the interpolated values are no more than estimated values. They do not represent any actually measured data values. When measuring a signal waveform, therefore, it is most recommendable to compare it with the waveform displayed in the real mode. This comparison can be rapidly accomplished simply by changing the STORAGE/REAL switch (30).

☆ Roll Mode

When in the regular mode (50 msec/DIV or over), the displayed waveform is not updated until storing of data is over. If a waveform is displayed at a very low speed when in the above condition, the waveform will take a long time before it is updated

and this will be inconvenient for waveform viewing. To solve this problem, the DSS5040 employs such system that, when the TIME/DIV switch (31) is set at a range lower than 0.1 sec/DIV, the waveform is displayed in a roll mode and sequentially updated as data is stored and, when the sweep is triggered, the stored data is re-arranged so that the triggered point conforms with the position selected by the TRIG POINT control (35).

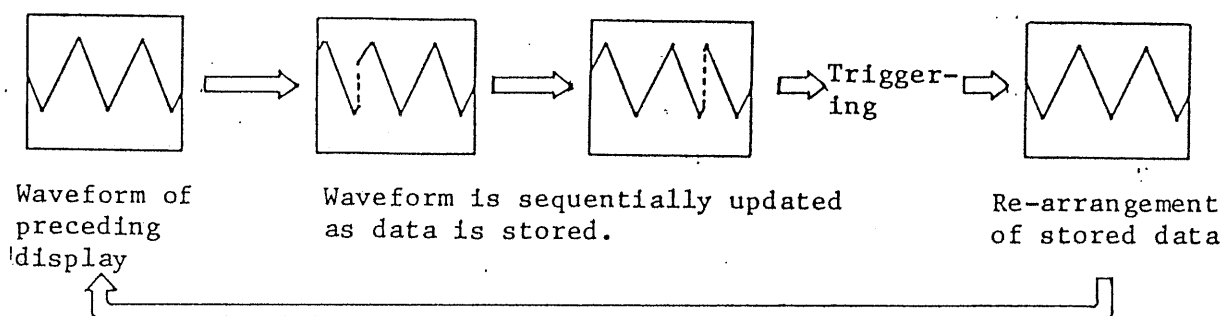

Figure 6-5. ROLL Mode

NOTE: If the SWEEP MODE selector (29) is set in the AUTO or NORM state, storing of waveform data resumes when a period of approximately 0.5 seconds has elapsed after triggering of sweep and re-arrangement of stored data is over. For more convenient viewing, by means of the VIEW TIME control (34), the displayed waveform can be held for a certain adjustable period of time (approximately 0.5 to 5 seconds) before starting storing of data for the next display.

2	To Save Waveform
---	------------------

- 1) In the STORAGE mode, display the waveform to be saved.
- 2) Press the SAVE switch (30). The waveform displayed at that instant will be saved, storing of data will cease, and the SAVE lamp (37) will illuminate.

3	To Magnify the Saved Waveform
---	-------------------------------

- 1) Save the waveform to be magnified.
- 2) Select a center of magnification with the TRIG POINT control (35).

863702

- 3) The displayed waveform can be magnified up to 100 times by setting the TIME/DIV switch (31) at a range faster than that with which the waveform has been saved. The set range of the TIME/DIV switch (31) directly is the time base for the magnified waveform display.

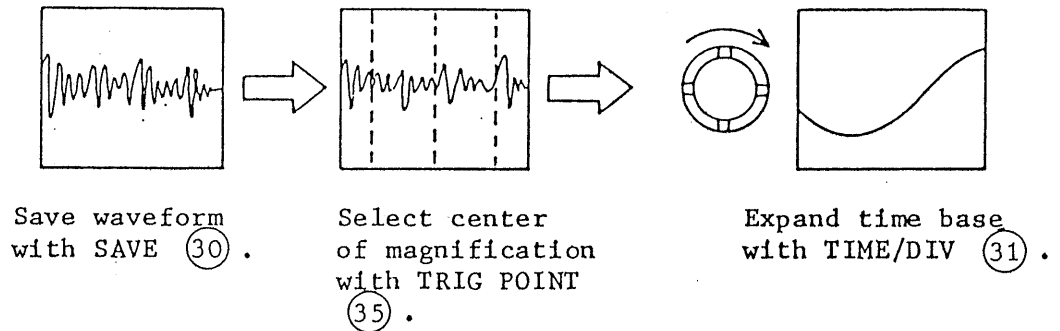

Note: If the display time base is slower than the save time base or if it is faster than 100 times of the save time base the displayed waveform blinks to indicate that it is invalid.

4	To Compare Waveforms
---	----------------------

- 1) Display a reference waveform and save it by pressing the REF switch (30).
- 2) Display a waveform to be compared. Align the two waveforms for comparison by using the vertical POSITION controls (9) and (21).

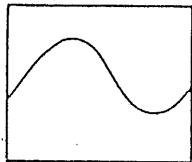

Save the reference waveform.
(REF (30))

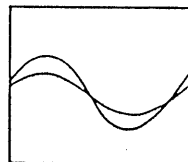

Display two waveforms overlappingly.
(POSITION (9) (21))

- o To update the reference waveform, press the REF switch once for resetting and then press it once more for saving.

5 To Save Waveform in Single-sweep Mode

- 1) Set the switches and controls as in the case of the real mode of 6.1 (6). While the oscilloscope is waiting for triggering as in the case of the real mode, data is continuously stored and the displayed waveform is continuously updated if the oscilloscope is set in the ROLL mode.
- 2) When triggering is effected, waveform data is re-arranged so that the triggered point conforms with that selected by the TRIG POINT control (35), and the re-arranged waveform is displayed and saved automatically.

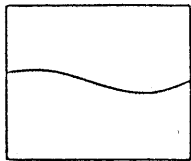

Ready for triggering, with preceding waveform displayed. (RESET (29))

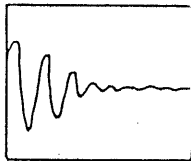

Triggering for single-sweep display. (Display only in ROLL mode)

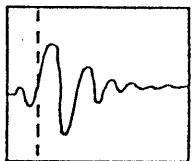

Waveform displayed and saved, being re-arranged for pre-selected triggering point.

- o The waveform saved in the single-sweep mode can be magnified as in the case of the regular save operation.

6 To View Waveform Existed Before Triggering

With conventional oscilloscopes (including storage-CRT oscilloscopes), waveform which existed before the triggering cannot be displayed because the sweep starts after triggering is effected. Although delay lines may be used to view the pre-triggering waveforms, up to several hundreds nanoseconds is the maximum with such provisions.

With the DSS5040, on the other hand, pre-triggering waveform can be observed for 2, 5, or 8 DIV of the graticule. This is realized as the DSS5040 constantly stores the input signal and the end point of storing is distated by the triggering signal. The range of the pre-triggering portion of the displayed waveform is selectable for 2, 5, or 8 DIV with the TRIG POSITION control (35).

863794

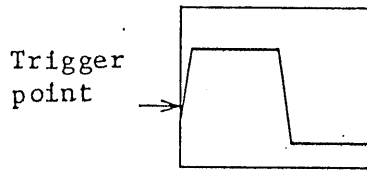

Conventional oscilloscope

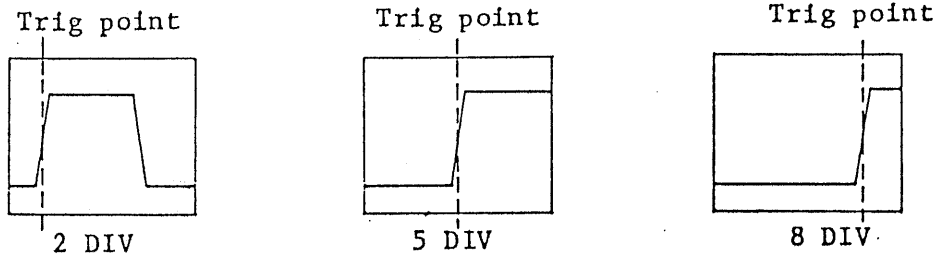

Digital Storage Oscilloscope

An example of setup for analysis of failures which occur at unpredictable instances, making use of the pre-triggering waveform display function together with the external triggering function and single-sweep function, is illustrated below.

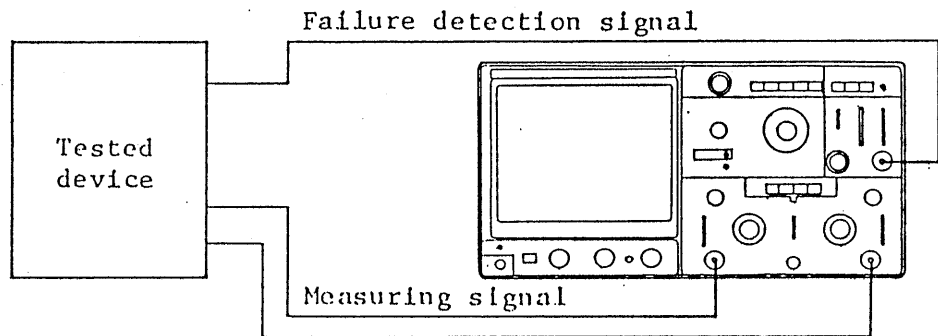

With the above setup and the oscilloscope set in the READY state for single-sweep, when the device failure detection signal is applied as a triggering signal, the oscilloscope automatically saves the measuring signal which existed immediately before the triggering. Thus, the required data even for a failure of which the time of occurrence is unpredictable can be successfully saved and the operator is relieved from constantly watching the CRT screen for an event of which occurrence time is unpredictable or which may not occur at all.

Note: When measurement is done in the above method, dual-channel simultaneous data acquisition can be done for the CHOP mode only.

863795

7 To Obtain Hardcopy of Waveform by PEN OUT Function

To obtain a hardcopy of the waveform displayed on a conventional oscilloscope (even that of a storage-tube type), it is necessary to photograph the waveform using a camera and this method is not very convenient. With the DSS5040, a hardcopy of the waveform can be obtained more conveniently by making use of the PEN OUT function and employing a X-Y recorder.

To make use of the PEN OUT function, proceed as follows:

- 1) connect the corresponding terminals of the DSS5040 and recorder. Set the recorder sensitivity with respect to the output voltage shown in the below chart.

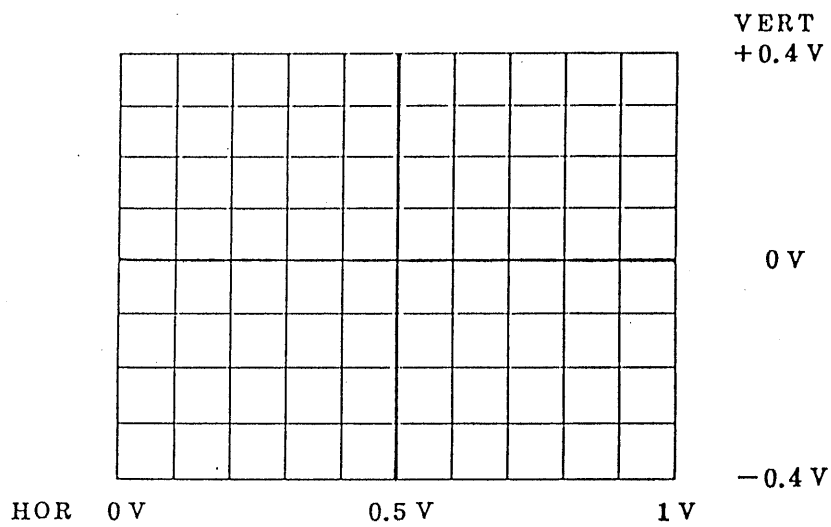

SYNC: TTL "HI" level when output is delivered

Job 16105 5/11 変更 DSS 5040

2) The saved waveform (including an enlarged waveform or a reference waveform) is delivered as shown below when the PEN switch (30) is pressed. When two waveforms are to be delivered, after the CH1 waveform is delivered, operation returns from (7) to (2) in order to deliver the CH2 or REF waveform.

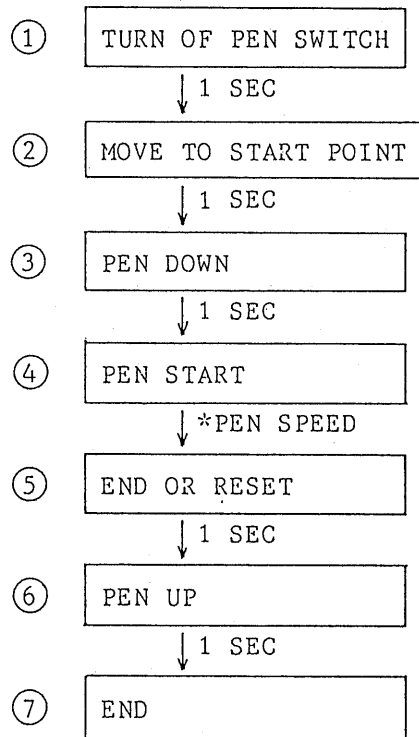

Waveform displayed on CRT

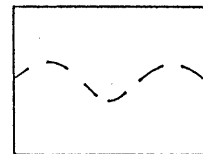

o Intensity-modulated waveform

(1)~(3) (5)~(7)

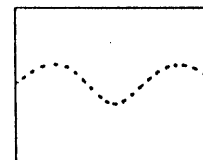

o Subdued-intensity waveform

(4)

*PEN SPEED

o Moving speed between points varies for approx. 55 msec - 4.4 sec depending on distance between points.

☆ Aliasing

One of the errors introduced when operating an oscilloscope at a range above its performance is aliasing. Aliasing is such phenomenon that, when the input signal frequency has become higher than a half of the sampling frequency, the input signal cannot be reproduced theoretically and the oscilloscope displays a waveform whose frequency differs from that of the input signal. For example, if an input signal of 4 Hz is digitized with a sampling rate of 3 Hz, a waveform of 1 Hz is displayed. One of the most effective means of identifying aliasing is to change operation of the oscilloscope to the real mode and check whether the frequency of the displayed waveform is definitely different from that of the input signal or not.

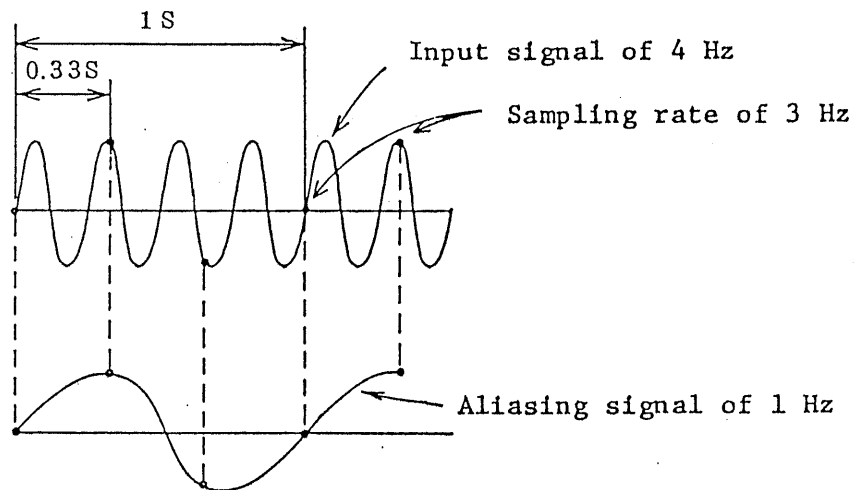

The sampling rate differs by the TIME/DIV range. Consequently, the frequency at which aliasing occurs differs by the TIME/DIV range.

There is another type of aliasing, namely, perceptual aliasing. This aliasing occurs even when the input signal frequency is lower than a half of the sampling frequency. As the input signal frequency becomes closer to a half of the sampling frequency, the nearest sampling point is erroneously taken for the next sampling point, thereby causing perceptual aliasing. Thus, perceptual aliasing differs from the true aliasing. Perceptual aliasing can be eliminated by magnifying the waveform by means of interpolation.

863798

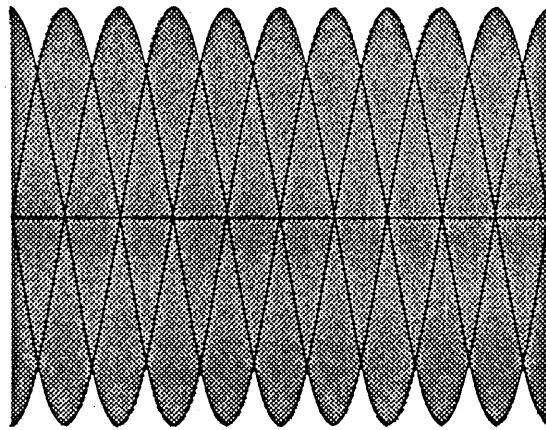

The frequency ranges within which the correct waveform measurement can be done without aliasing are shown in the following table. The values shown in the table may be effectively utilized in such cases that waveforms are displayed in the one-sweep mode.

TIME/DIV (31)	Frequency (Hz)	TIME/DIV (31)	Frequency (Hz)
1 sec	DC - 28	0.5 msec	DC - 56K
0.5 sec	DC - 56	0.2 msec	DC - 140K
0.2 sec	DC - 140	0.1 msec	DC - 140K
0.1 sec	DC - 280	50 μ sec	DC - 280K
50 msec	DC - 560	20 μ sec	DC - 700K
20 msec	DC - 14K	10 μ sec	DC - 1.4M
10 msec	DC - 28K	5 μ sec	DC - 2.8M
5 msec	DC - 56K	2 μ sec	DC - 7M
2 msec	DC - 14K	Up to 0.2 μ s	DC - 7M
1 msec	DC - 28K		

100.8.24

863799A

7. OPERATING PRINCIPLE

7.1 Basic Principle of Digital Storage Oscilloscope

7.1.1 Digital Storage Oscilloscope

The term "storage oscilloscope" in the past was applied to an oscilloscope which employed a storage CRT. This type of oscilloscope stores the displayed waveform by the function of the cathode-ray tube itself.

Recently, digital storage oscilloscopes have become available. The basic principle of this type of oscilloscope is as shown in Figure 7-1.

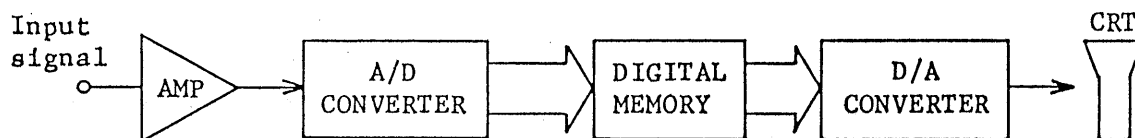

Figure 7-1. Basic Principle of Digital Storage Oscilloscope

As shown in Figure 7-1, the analog input signal is converted into a digital signal data and stored in a digital memory. To reproduce the waveform on the CRT, the data stored in the memory is sequentially read and converted into an analog signal in order to be displayed on the CRT. By reading the data at a frequency higher than causing flicker (at a frequency of 50 Hz or over), the read data can be displayed as a flickerless stationary waveform on the CRT screen.

7.1.2 A/D Converter

The A/D converter converts the analog input signal into a digital signal in order to be stored in the digital memory. The amplitude of the analog signal continuously vary by time. For conversion into a digital signal, the analog signal should be sampled at certain intervals. Each of the sampled analog signal is quantitized into a digital signal. See Figure 7-2.

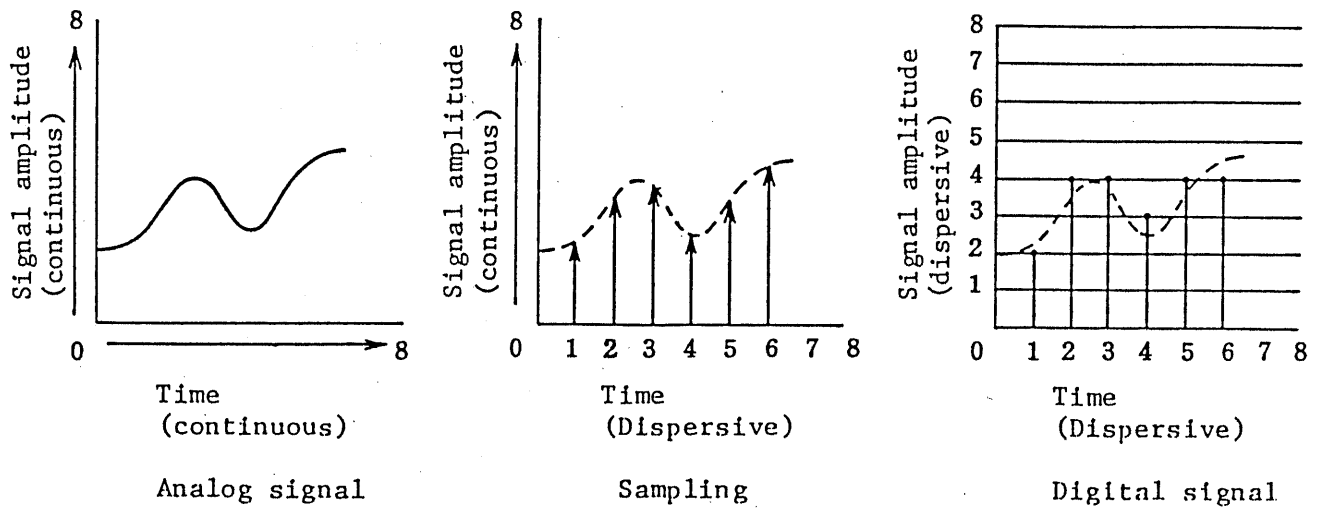

Figure 7-2. A/D Converter

7.1.3 Digital Memory

The analog signal quantitized into a digital signal by the A/D converter is stored in the digital memory. The digital quantities of the signal shown in Figure 7-2 for example are as shown in Table 7-1. These quantities as data values are stored at respective addresses of the digital memory.

Table 7-1. Time and Data

Time	1	2	3	4	5	6
Data	2	4	4	3	4	4

7.1.4 D/A Converter

In order to be displayed as an analog signal, the digital data stored in the digital memory is converted back into analog values by the D/A converter. The function of the D/A converter is in the reverse of that of the A/D converter.

7.2 Circuit Structure

The circuit structure of the DSS5040 is as shown in the block diagram of Figure 7-3. The major blocks are the vertical deflection circuit, horizontal deflection circuit, data acquisition and processing circuit,

CRT circuit, CAL circuit and power supply circuit. Individual circuits are described in the subsequent paragraphs.

7.2.1 Vertical Deflection Circuit

The vertical deflection circuit is for vertically deflecting the beam spot on the CRT screen. The input signal is impedance-converted and amplified by the CH1 or CH2 preamplifier to a level suitable for driving the subsequent stage of the circuit. The channel selector selects the channel to be used, being controlled by the CPU. Then the signal is fed to the STORAGE SIGNAL PICKOFF circuit. The signal picked off is fed to the A/D converter. The vertical mode selector selects either the storage signal or real signal. The selected signal is fed to the vertical output amplifier which amplifies the signal to a sufficient level for vertically deflecting the CRT beam.

7.2.2 Horizontal Deflection Circuit

The horizontal deflection circuit is for horizontally deflecting the beam spot on the CRT screen. It has a trigger circuit and a sweep circuit. It operates also as an X-axis deflection circuit for X-Y operation.

The trigger generator selects either the signal fed from the channel selector or the EXT TRIG signal, and generates a triggering signal for sweep and an AUTO signal to indicate existence/absence of the triggering signal.

When in the X-Y mode or EXT HOR mode, the circuit operates as an X-axis amplifier.

The real mode sweep generator generates a sweep signal for operation in the real mode, being synchronized with the triggering signal.

The horizontal mode selector selects the storage mode sweep signal, the real mode sweep signal, or the X-axis signal. The selected signal is amplified by the horizontal output amplifier to a sufficient level for horizontally driving the CRT beam.

863802

7.2.3 Data Acquisition & Processing Circuit

This circuit converts the analog input signal into a digital signal for storage and renders interpolation on the stored data for reproduction of the analog signal on the CRT screen. The various data items fed through the I/O port are read by the CPU which provides the control signals for the various circuits. The waveform data fed from the A/D converter is stored in the main memory. The CPU provides interpolation and other processings on the data. The processed data is transferred to the display memory. Except during the transfer periods, the contents of the display memory are constantly sent to the D/A converter and displayed on the CRT.

7.2.4 CRT Circuit

The CRT circuit provides the high voltages for the CRT and controls the Z-axis of the CRT. The Z-axis amplifier amplifies the Z-axis signal to a sufficient level for controlling the brightness of the CRT beam spot. The HV regulator provides a high voltage for the CRT. The voltage is controlled by the CRT control circuit via the Z-axis output amplifier, to control the CRT beam spot intensity and focus.

7.2.5 CAL Circuit and Power Supply Circuit

The CAL circuit provides a reference signal for calibration of the probe and for operation of the amplifiers in the non-calibrated state. The reference signal is a square wave of 0.5 Vp-p, with voltage accuracy better than 2%.

The power supply circuit provides supply voltages (145V, 12V, -12V, and 5V) for the various circuits of the oscilloscope.

8. MAINTENANCE AND STORING

The DSS5040 employs precision components and high voltage parts. Exercise care when transporting or storing it.

To clean the filter and front face of CRT:

To clean the filter and the front face of CRT, remove the filter as illustrated below and clean them using a soft cloth.

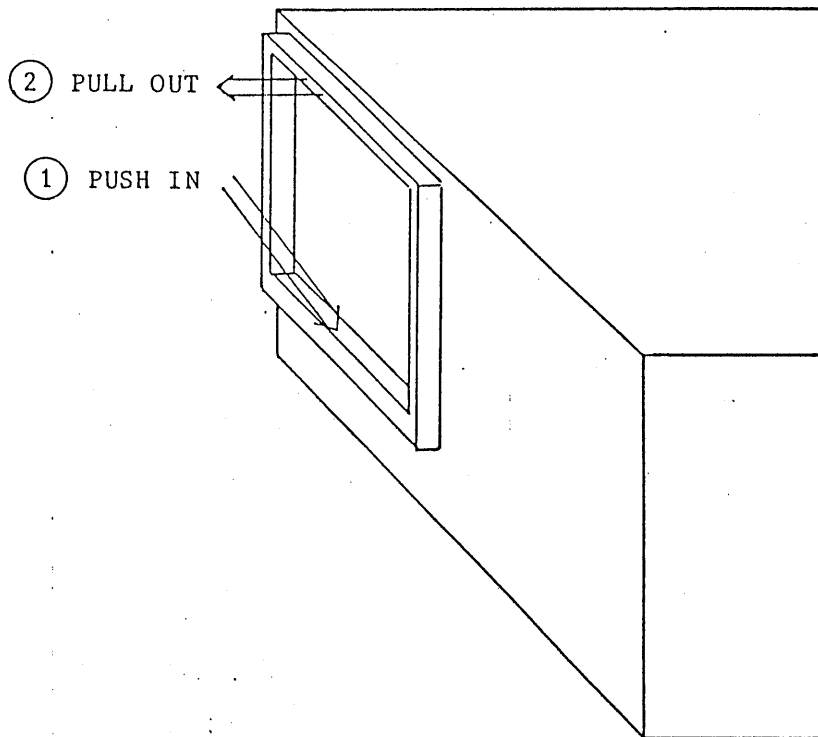

863805

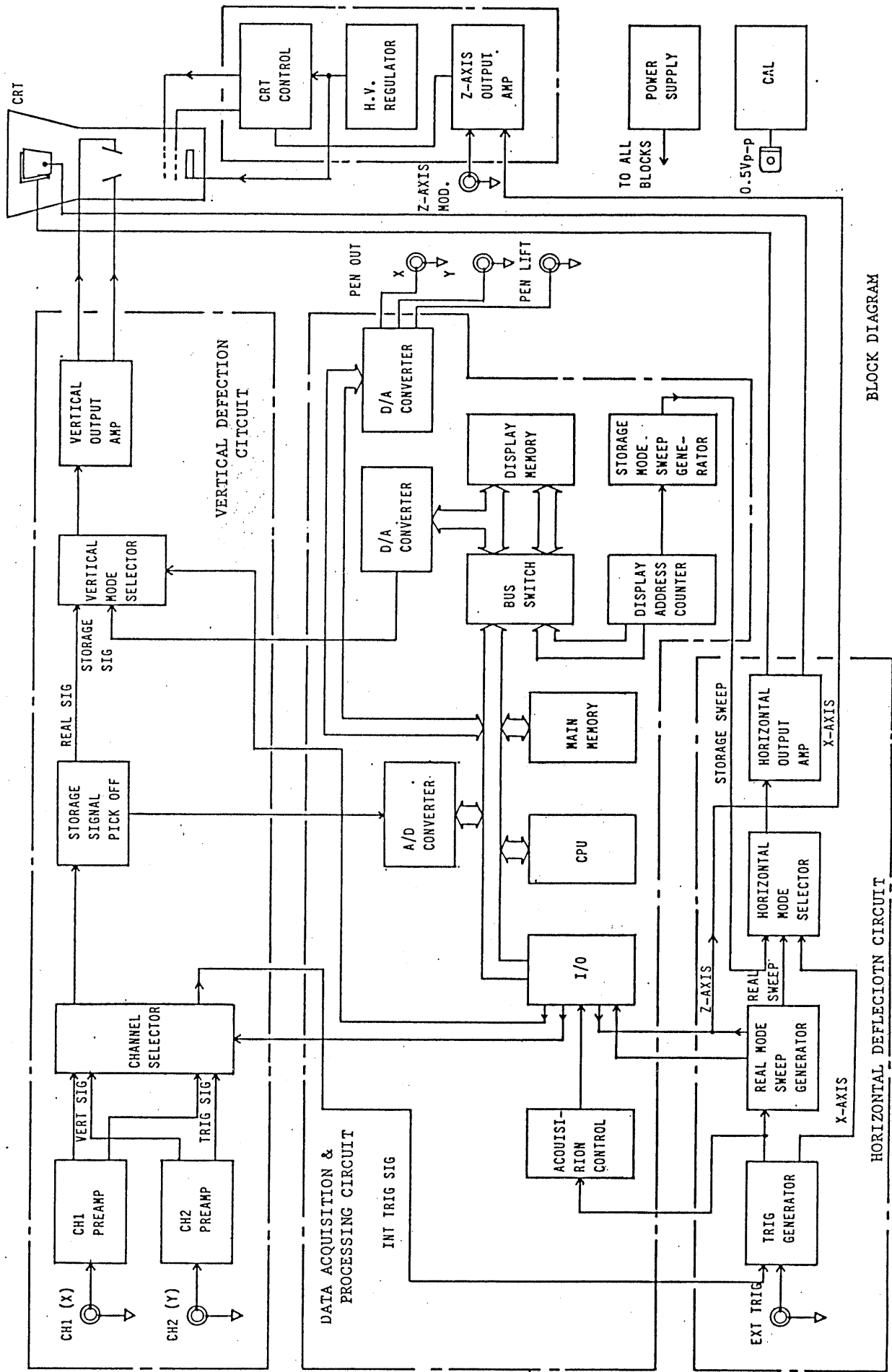

BLOCK DIAGRAM